

TWELVE EASY GEMSTONE FACETING DESIGNS

A GUIDE FOR THE BEGINNER GEMCUTTER

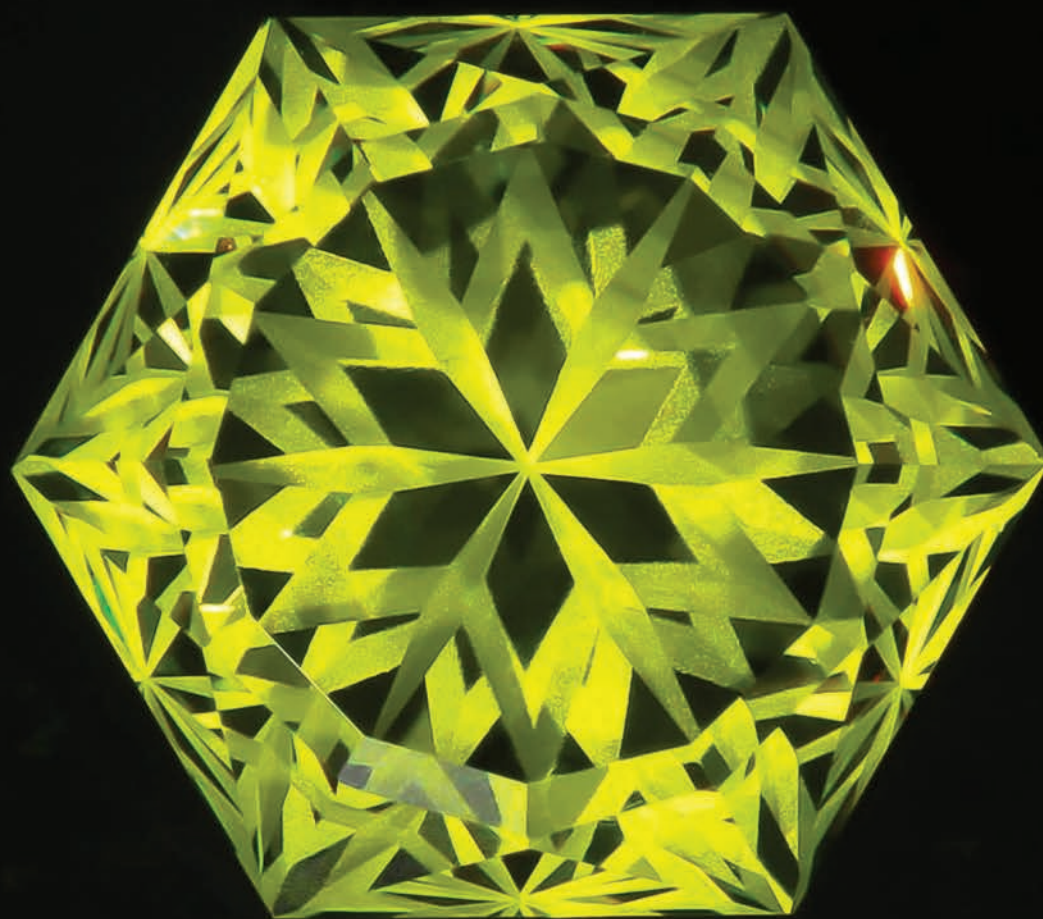

ANDREW IAN BROWN

MARK OROS

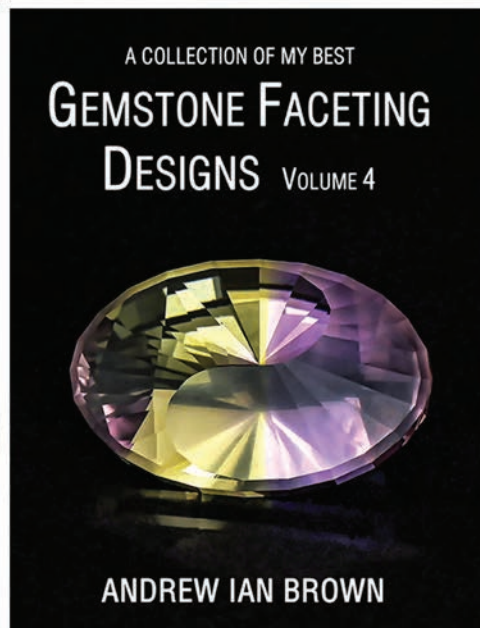
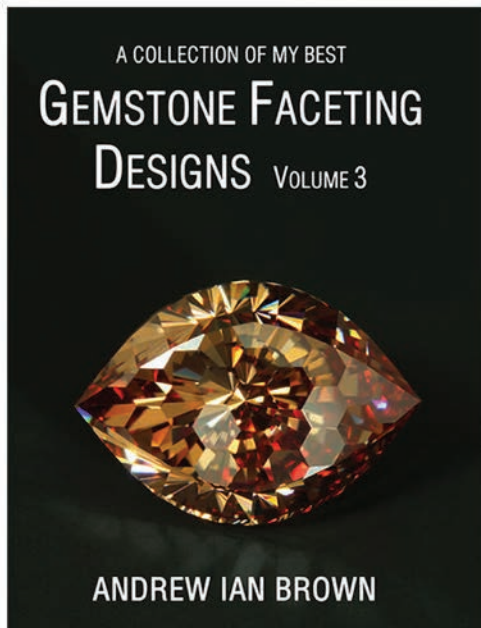
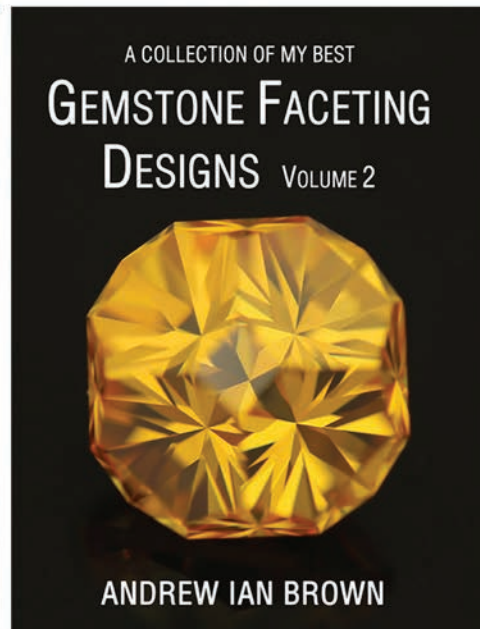
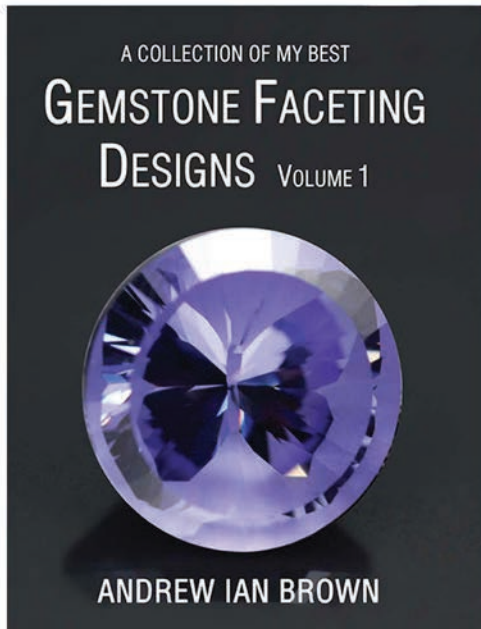

Please visit facetingdesigns.com for more faceting designs by Andrew Brown

Copyright © Andrew Ian Brown, 2022 All rights reserved.

Copyright © Mark Oros, 2022 All rights reserved.

The authors hereby disclaim all liability, including consequential damages which may result from using these materials, and any liability to any party for any loss, damage, or disruption caused by errors or omissions. Whether such errors or omissions result from accident, negligence, or any other cause. Persons who use these materials do so at their own risk. The authors hereby disclaim all liability, including consequential damages which may result from using these materials and any liability to any party for any loss, damage, or disruption caused by errors or omissions. Whether such errors, or omissions result from accident, negligence, or any other cause. Persons who use these materials do so at their own risk.

“Excellence is the path, not a destination.” — Mark Oros

Hashnu Stones & Gems is a full service lapidary studio providing private gemstone faceting lessons and ULTRA TEC equipment. Mark is available to help you get started faceting gemstones and to work with you on setting up your lapidary/faceting studio with ULTRA TEC faceting machines. Please feel free to contact Mark at mark@hashnustones.com



Contents

- Foreword..... 1
- Refractive Index and Critical Angle 2
- Symbols and Abbreviations..... 3
- Faceting Your First Twelve Gemstones: Practice, Practice, and Practice 4
- A Beginner’s Guide for Buying Facet-Grade Rough Gemstones..... 6
- 1. Nonagon
 - Brilliant 93 AIB251 9
- 2. Pentagon
 - Five Steps AIB252 13
- 3. Trillion
 - Trioptic Blast AIB253..... 17
- 4. Marquise
 - Easy Cut Marquise AIB254..... 21
- 5. Square
 - Little Princess AIB255 25
- 6. Pear
 - Seven Star Pear AIB256 29
- 7. Decagon
 - DecaCheck Two AIB257..... 33
- 8. Shield/Heart
 - Shield Of The Heart AIB258 37
- 9. Oval
 - Beginner Oval 1.40 AIB259 41
- 10. Round
 - Six Star Brilliant AIB260 45
- 11. Rectangle
 - 150 Emerald AIB261 49
- 12. Hexagon
 - Frost Star Hex AIB262 53

Foreword

It is my pleasure to present the results of the collaboration between myself and Mark Oros. For those of you who don't know Mark, he spends his time faceting gemstones and promoting the art and craft of lapidary at the Hashnu Stones & Gems studio in the Finger Lakes region of New York State. Mark provides custom gemstone faceting, colored gemstone consulting services, and private faceting lessons. He is also a representative for ULTRA TEC faceting equipment. You can contact Mark by messaging him through his social media sites, [instagram.com/hashnustones](https://www.instagram.com/hashnustones) or [facebook.com/hashnustones](https://www.facebook.com/hashnustones), or using the contact form on his website, www.hashnustones.com

For a long time, I had been considering producing a book for beginners. When Mark contacted me asking if I was interested in creating some designs for his students, I jumped at the opportunity and the concept of this book was born.

The designs in this book are presented in order of increasing difficulty, slowly introducing the beginner to different faceting styles while cutting a wide range of shapes. Even though most of these designs have a low facet count, all have excellent performance with many using odd symmetry to create scintillation and interesting patterns. The final design, pictured on the front cover, is a little trickier to cut than the first 11, as it uses "facet-frosting" to create the pattern. After cutting the preceding designs and reading the cutting notes, I am hopeful this design won't prove too much of a challenge.

For the beginner, it is recommended that you facet these designs in the order presented. You are welcome to repeat a design before moving on to the next design. Please refer back to the "Faceting Your First Twelve Gemstones" article frequently for guidance. If you are having reoccurring faceting issues I suggest contacting your faceting instructor or use the many faceting references and support groups online. It is also recommended that you join one or both of the following organizations along with any local lapidary or faceting club. usfacetersguild.org facetorsguild.com.au

Some notes for those new to my books:

- When designing I tend to alternate between GemCad, GemRay and Gem Cut Studio (GCS). Gem renderings contained herein are represented with a 10-degree head shadow and using "Random" lighting models, which I find gives a fairly accurate rendering of the completed gem. My test cutting has confirmed this, and I am confident in the performance of the designs I present.
- In my books, I use multiple optimizations indicated by "A", "B", "C" etc, these can be found in the instruction table headings. Creating these multiple optimizations has taken a fair bit of time, but fine-tunes the angles for better results. So please before you cut, look up the RI of the material you plan to cut in the table on page 2 of this book, and match that to the angle sets provided in the cutting instructions for best results.
- For ease of cutting, my designs generally follow the principles of meet point faceting, although a number have float in tiers late in the cutting sequence. I devote considerable attention to sequencing and annotating the designs I create so that you the faceter have the best chance of successfully cutting them.

Please feel free to contact me at facetingdesigns@gmail.com with feedback, comments, questions, or even design requests.

My webpage facetingdesigns.com contains:

- Details on book content, including sample renderings and images of cut stones.
- Links for purchasing my other books.
- Free designs and other information.

I hope you enjoy these faceting designs.

Andrew Brown

Refractive Index and Critical Angle

Gemstone	Refractive Index	Double Refraction	Critical Angle
Alexandrite	1.746 – 1.755	0.008 – 0.010	34.74 – 34.94
Almandine garnet	1.770 – 1.820	none	33.33 – 34.40
Amethyst	1.544 – 1.553	0.01	40.08 – 40.37
Andradite garnet	1.88 – 1.94	none	31.03 – 32.13
Apatite	1.628 – 1.649	0.002 – 0.006	37.33 – 37.90
Aquamarine	1.564 – 1.596	0.004 – 0.005	38.80 – 39.75
Beryl	1.562 – 1.602	0.004 – 0.010	38.62 – 39.81
Chalcedony	1.530 -1.540	0.004 – 0.009	40.49 – 40.81
Chrysoberyl	1.746 – 1.763	0.007 – 0.011	34.56 – 34.94
Chrysoprase	1.530 -1.540	0.004 – 0.009	40.49 – 40.81
Citrine	1.544 – 1.553	0.01	40.08 – 40.37
Clear quartz	1.544 – 1.553	0.01	40.08 – 40.37
Cubic zirconia	2.150 – 2.180	none	27.30 – 27.72
Danburite	1.630 – 1.636	0.006 – 0.008	37.68 – 37.84
Diamond	2.417 – 2.419	anomalous	24.42 – 24.44
Diopside	1.664 – 1.730	0.024 – 0.031	35.31 – 36.94
Emerald	1.565 – 1.602	0.01	38.62 – 39.72
Fluorite	1.43	none	44.21
GGG	1.970 – 2.020	0.06	29.67 – 30.51
Glass	1.44 – 1.90	none	31.76 – 43.98
Iolite	1.542 - 1.551	0.01	40.15 – 40.43
Labradorite	1.559 – 1.570	0.008 – 0.010	39.56 – 39.90
Lithium niobate	2.200– 2.280	0.071 – 0.107	26.01 – 27.04
Moissanite	2.650 – 2.690	0.313	21.82 – 22.17
Moonstone	1.518 – 1.526	0.01	40.94 – 41.21
Opal	1.37 – 1.52	none	41.14 – 46.88
Peridot	1.650 – 1.703	0.036 – 0.038	35.96 – 37.31
Prehnite	1.611 – 1.669	0.021 – 0.039	36.81 – 38.37
Pyrope garnet	1.720 – 1.756	none	34.71 – 35.55
Rose quartz	1.544 – 1.553	0.01	40.08 – 40.37
Ruby	1.762 -1.778	0.01	34.22 – 34.58
Rutile	2.616 – 2.903	0.29	20.15 – 22.47
Sapphire	1.762 – 1.778	0.01	34.22 – 34.58
Scapolite	1.531 – 1.600	0.004 – 0.037	38.68 – 40.78
Smoky quartz	1.544 – 1.553	0.01	40.08 – 40.37
Spessartine garnet	1.790 – 1.820	none	33.33 – 33.96
Sphalerite	2.369 – 2.371	none	24.95 – 24.97
Spinel	1.712 – 1.762	none	34.58 – 35.74
Sunstone	1.525 – 1.548	0.01	40.24 – 40.98
Tanzanite	1.691 – 1.700	0.01	36.03 – 36.25
Topaz	1.609 – 1.643	0.008 – 0.016	37.49 – 38.43
Tourmaline	1.614 – 1.666	0.014 – 0.032	36.89 – 38.29
YAG	1.833 – 1.835	none	33.02 – 33.06
Zircon	1.810 – 2.024	0.0002 – 0.059	29.61 – 33.54

* Source - gemsociety.org

Symbols and Abbreviations

Gemstone Diagram Dimension Symbols

Symbol	Description
C	Crown height
P	Pavilion depth
L	Length
W	Width
D	Diagonal distance
T	Table length
U	Table width

Gemstone Cutting Instructions, and Diagram Labeling

Indicative abbreviation	Description
C1, C2, C3, ...	Crown facet tiers
P1,P2, P3, ...	Pavilion facet tiers
G1, G2, G3, ...	Girdle facet tiers
PF1, PF2, PF3, ...	Preform facet tiers
T	Table facet
C	Culet
FCP	Final center point
TCP	Temporary center point
MP	Meet point
RI	Refractive index
RI range	Refractive index range for materials the design suits
RI diagram	Refractive index range for the diagrams shown

Faceting Your First Twelve Gemstones: Practice, Practice, and Practice

by Mark Oros

How does a new faceter best learn the craft and art of faceting gemstones after faceting their first gemstone? There are great books, manuals, and videos that tell you how to facet your first gemstone. I give four-day lessons where the student facets two gemstones in my studio as well as Zoom lessons where the student cuts one gemstone. These work well for understanding the process of gemstone faceting, but where does one go from there? How does one develop great gemstone faceting skills? This listicle is meant to help beginning faceters progress during the first twelve weeks of faceting, solving common problems, and providing tips that I apply to my daily gemstone faceting.

After learning how to cut your first stone with a teacher and attempting to cut a stone alone, things may not go as well as in the lesson. Understand that gemcutting is a trade, and like many trades, there is a learning curve. Gemstone cutting is still considered a guild in many parts of the world and has a progression from apprentice, journeyman, to master. In a guild or studio, the apprentice gradually learns the craft by taking small steps and repeating the skills over and over again. It is by measured advancement and practice that the skills develop and one achieves their gemstone faceting goals. Here are my recommendations for my students when they get home, set up, and are ready to start their faceting journey.

1. Monitor your progress, each gemstone that you facet should be better than the previous one. Your skills will develop over time and as long as you are progressing by making better gemstones with each effort, then you are moving in the right direction. Even today, my motto is, "Every gemstone needs to be better than the last." This keeps me actively developing and refining my faceting skills.
2. Practice, practice, and practice. Gemstone faceting is a skill that needs time to develop. It is not unlike learning to create a stained glass window, throw a clay pot, or paint a picture. One must develop their skill set through practice and refinement. Louis Comfort Tiffany, Peter Voulkos, or Georgia O'Keeffe did not turn out masterpieces on their first tries and neither will you. It takes a minimum of seven to twelve gemstones to start to understand and work through the issues of basic gemstone faceting.
3. Start with 10 mm rough gemstones. This size allows you to see what you are doing. It's not so large that it takes a long time and not so small that the gem will disappear if you make a mistake. I recommend using light smokey quartz because it is easier to see facets than clear quartz and is inexpensive. If you want to see where you have faceted during the process, cover your gemstone with pencil between cutting laps.
4. Advice and recommendations will come from many sources. Like any opinion that someone gives you, including mine, what you read, see, and hear from other faceters can be either right or wrong for you. Beware of the individual that is adamant about their way being the only way. Your faceting journey is about finding your own way. What works for others may not work for you. Also, do not spend too much time reading books, stalking user groups, and watching videos. Balance your time wisely, making sure that you spend most of your time cutting. The only way to learn to facet is to facet. Today's information generation tends to over-study and analyze rather than practice and perform. Of course, if you are waiting for your equipment to show up, go ahead and read Tom Herbst's book, "Amateur Gemstone Faceting Volume 1", a couple of times through.
5. Many new faceters find it helpful to keep a journal for tracking failures and successes. After each design in this book, there is a page for you to write notes.
6. Start with simple round brilliant designs and progress to harder designs as you improve. Don't overstep your progress by taking leaps. Baby steps are fine for your first twelve gemstones. I highly recommend "Learn to Facet the Right Way" by Jeff Graham.

7. You need to trust your faceting machine. Many times I talk to a beginner and owner of a new ULTRA TEC faceting machine and I will hear them blaming the faceting machine or laps for their problems. These folks have only cut one to three gemstones. The machine is most likely not the problem. The problem is that they are neophytes. It is a simple matter of them not having put in the time to learn the craft yet. ULTRA TEC is my faceting machine of choice. I not only highly recommend them, I also sell them and help new faceters put together their equipment, supplies, and rough gemstones to get started faceting. When you buy a good faceting machine, trust it to do its job while you learn yours.
8. In a sense, all faceting is doing is taking out larger scratches with smaller scratches up to the polished state. It is very important to look at your gemstone facets and make sure that previous lap scratches are being removed while you meet and align your facets. My students tell me they hear about faceters skipping laps/grits and taking shortcuts. I have never seen the advantage of this method. I believe that each lap/grit takes you on a gradual path to facet alignment and polish. To skip a lap/grit is to deny yourself of the benefit that a lap has in the faceting process. Skipping laps/grits can wear out laps and limit your precision and make polishing a chore. Here again, there are different opinions, but I suggest that you don't skip laps until you are confident with your faceting and satisfied with your finished gemstones. Shortcuts are best taken by those that know the terrain.
9. Watch what each lap is doing to your facets. Make sure that the laps are clean and not contaminated and are taking out scratches and not putting larger ones into your gemstone. It is very common for a new faceter to think that the scratches were left from the previous lap when the lap they are using needs to be cleaned.
10. Your girdle, pavilion girdle facets, and crown girdle facets are the foundation for your gemstone. It is from these initial tiers that the rest of the gemstone is aligned in meet-point faceting. I find it is useful to go around these tiers two or three times on each lap (excluding pre-polishes and polish) to set the foundation for all other facets.
11. It takes a little longer to go around the tiers again, but it saves me time putting in the following facets.
12. Take care of your faceting machine, laps, and workspace and they will take care of you.
13. If you have a problem that keeps repeating itself, stop and ask for help in identifying the source of the problem. There is a wonderful set of faceters in our community that would be happy to help. The only question unanswered is the one not asked. When in doubt, ask about.
14. Don't hurry the dopping process. Make sure the dop and gemstone have significant surface area contact. Make sure the surfaces are clean and oil-free. Let the glue set overnight.
15. When buying rough, I recommend that you start slowly and cautiously, and learn about purchasing rough to prevent costly mistakes. Ask your colleagues for rough dealer recommendations. Make sure the rough dealer has a return policy. Inspect your rough upon receipt and acknowledge your satisfaction or disappointment with the rough dealer the same day as receipt. If a deal seems too good to be true from an unknown seller, be wary.
16. Set realistic expectations and goals for your learning period. Try to facet as much as possible right away so you can get some momentum going and start feeling proud of your faceting. There may be times that you have to step away from the faceting machine because of frustration. Come back with a clear head and a relaxed state to put you back into the groove.

Remember, your first twelve gemstones are practice. They don't need to be perfect and you don't have to spend a lot of time on each one. Keep the queue moving while you learn your craft. Wait until you create a gemstone that you are proud of before showing it off. Above all, enjoy your faceting journey.

Mark Oros is a gemcutter, lapidary instructor, and owner of the HashnuStones and Gems LLC.

[instagram.com/hashnustones](https://www.instagram.com/hashnustones)

www.hashnustones.com

A Beginner's Guide for Buying Facet-Grade Rough Gemstones

By Mark Oros

The following guidelines are what I recommend to my faceting students when buying gemstone rough for faceting gemstones. I like to call them the Four P's of Facet Rough.

Practice Gemstones - This is the gemstone rough that you will use to learn how to facet. I suggest buying a variety of different materials and sizes that will match the 12 designs included in this document.

Portfolio Gemstones - This is the gemstone rough that you will facet and show to your potential clients. You will need to have examples of your work in order to give your clients an idea of your style and technical capabilities. These gemstones are for sale, but you will need to keep a reasonable portfolio until you are established.

Purchase Gemstones - This is the gemstone rough that you will use to fill purchase orders from your clients. This gemstone rough will be faceted only when receiving an order. You may prefer to have a large inventory of faceted gemstones. I prefer to cut the gemstones upon request and use my Portfolio Gemstones for immediate sales.

Passion Gemstones - This is the gemstone rough that you need no serious justification to purchase. These rough gemstones are about your passion for the craft. I like to think of these gemstones as the reward for my successful selling of finished gemstones.

General Recommendations:

1. Set a budget for buying facet rough. Keep in mind that you are in the finished gemstone business and not the rough gemstone commodity business. I like to take a percentage of my finished gemstone sales and allocate it to purchasing new gemstone rough.
2. Only buy from rough dealers that have a reasonable and documented return policy.
3. When buying gemstone parcels at a show, look through the whole parcel.
4. PayPal works for 98% of my buying and selling transactions. I personally avoid using Western Union and fund transfer apps that I do not recognize.
5. When working with a new rough dealer, ask for client references.
6. If the deal is too good to be true, it is probably a scam.
7. I avoid buying from individuals that have no website, no social media, or no proven experience.
8. Consider going in on a large parcel with your colleagues.
9. Cultivate a good relationship with your rough dealer.
10. Use the four P's for guidance when buying rough gemstones for faceting.

Exceptions:

1. I recommend buying rare or seldom seen gemstone rough when it is available.
2. If the price is right, I like to buy a limited amount of additional stock for a rainy day.

I have been in the gemstone rough business for many years and recently sold my facet rough stock so I can focus more time on faceting gemstones. I sold my facet rough inventory to **storiedgemstones.com** and highly recommend working with them.

1. Nonagon

Design name: Brilliant 93

Number of facets: 31

Description:

This is an easy-to-cut simple round design for the beginning faceter. It is not a perfect equal-sided nonagon as it uses 3-fold symmetry on the 96 index to create the shape. The 3-fold odd symmetry creates nice scintillation from a small number of facets. The word nonagon is derived from the Latin prefix, “nona”, meaning nine, and the Greek suffix, “gon,” meaning sides.

Notes:

- On the following page, you will see this design has two angle optimizations, “A” and “B”. Use the table on page 2 to identify the refractive index (RI) of the gemstone rough you are planning to use and select the appropriate set of angles to cut.
- Take care to form a final center point (FCP) perfectly. This will be the base of the stone and the girdle and crown will be built off it.

Brilliant 93

AIB251

© Andrew Brown
July 2022

Design Information	
Pavilion facets	9
Girdle facets	9
Crown facets	12+1
Total facets	31
Index gear	96
Symmetry	3-fold mirror image
RI range	1.54 to 2.20
RI diagram	1.54 to 1.70
L/W = 1.025	T/W = 0.542
U/W = 0.470	P/W = 0.430
C/W = 0.140	V/W ³ = 0.208

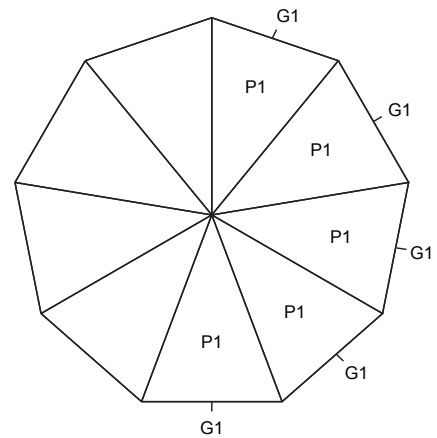
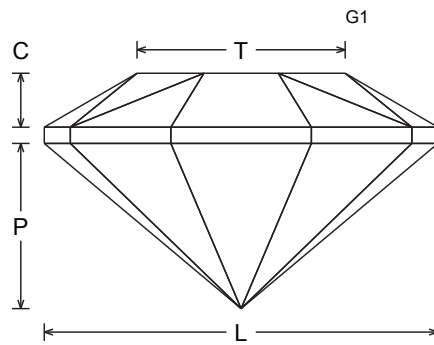
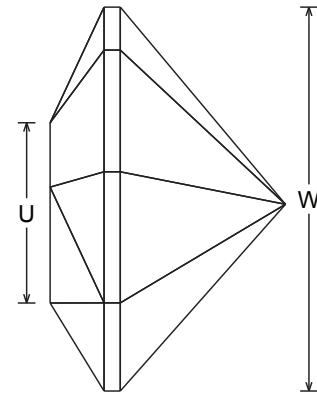
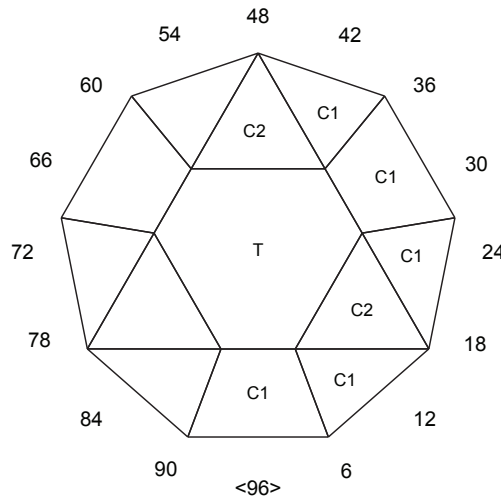

Pavilion *A = RI 1.54 to 1.70 B = RI 1.70 to 2.20

Facets	A	B	Index	Instructions
P1	41.50°	40.70°	96-11-21-32-43-53-64-75-85	Form FCP
G1	90.00°	90.00°	96-11-21-32-43-53-64-75-85	Set stone size. Establish a level girdle

Crown *A = RI 1.54 to 1.70 B = RI 1.70 to 2.20

Facets	A	B	Index	Instructions
C1	31.50°	31.50°	96-11-21-32-43-53-64-75-85	Establish girdle width
C2	25.00°	25.00°	16-48-80	Meet G1, C1
T	0.00°	0.00°	Table	Meet C1, C2

Please visit facetingdesigns.com for more faceting designs by Andrew Brown

RI = 1.54

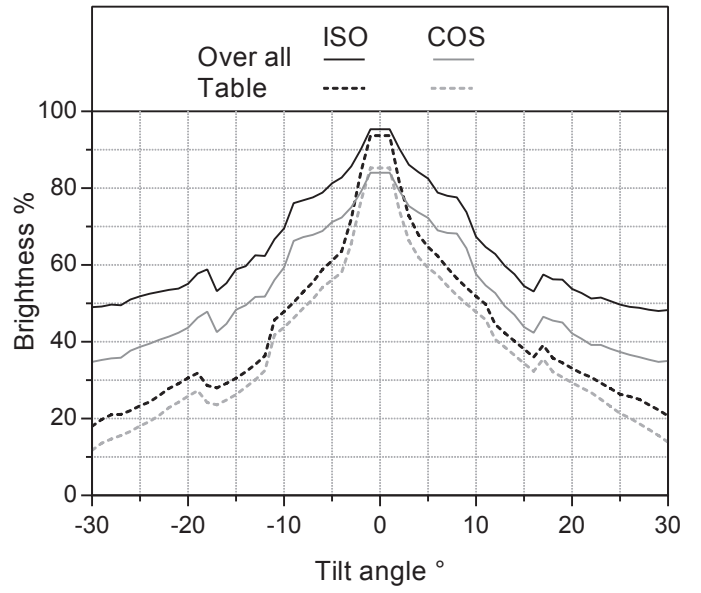

RI = 1.76

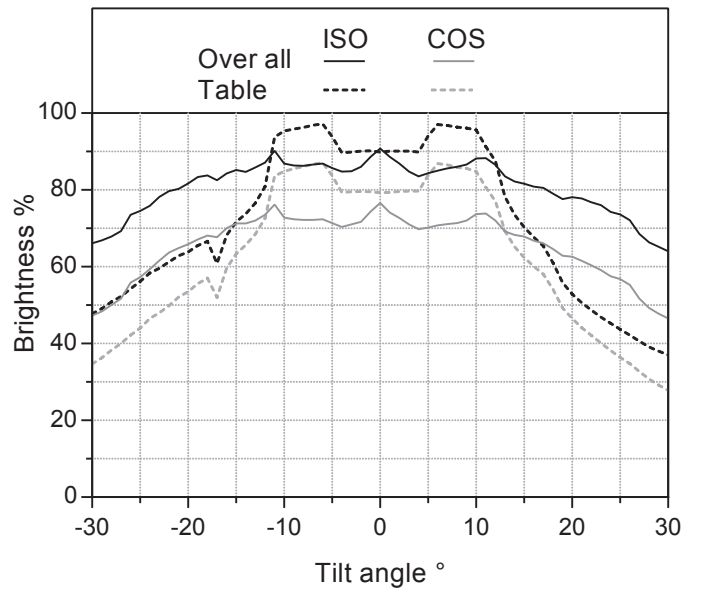
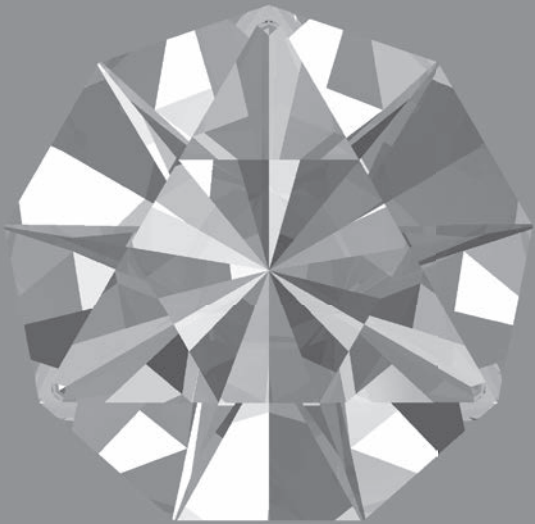

RI = 2.16

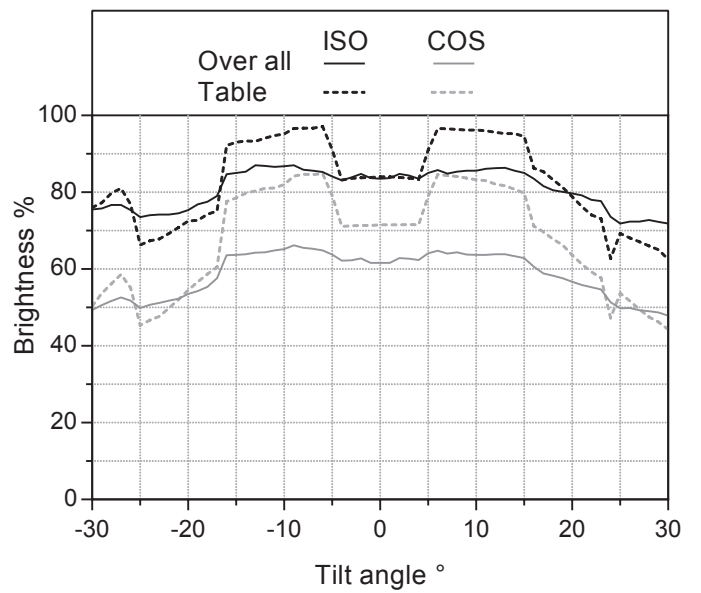

2. Pentagon

Design name: Five Steps

Number of facets: 21

Description:

The name pentagon is derived from the Greek, “pente,” meaning five, and “gonia,” meaning angles. I have looked and can’t find any, but given the simplicity of this design, other similar pentagon designs may exist for the 80 or 120 indexes. This design is a pentagon using the 96 index. It is not perfectly symmetrical as 96 is not divisible by 5, but it is close enough to get the benefits of 5-fold odd symmetry. This is a great introduction to cutting a stepped crown.

Notes:

- Getting your transfer spot on is important when cutting stepped crowns. If your transfer is off, you will find it hard to get even crown step facets and to keep the girdle width constant. It might be worth choosing to polish your girdle after transferring the stone in order to check the stone’s alignment. If it isn’t perfect, adjust it using your machine’s fine adjustment(cheater) before cutting the crown facets.
- This design will be forgiving if you don’t get the steps and table the same as the diagram. If the proportions of the crown steps and table don’t match the diagram exactly, your finished stone will still look nice.

Five Steps

AIB252

© Andrew Brown
July 2022

Design Information	
Pavilion facets	5
Girdle facets	5
Crown facets	10+1
Total facets	21
Index gear	96
Symmetry	1-fold mirror image
RI range	1.54 to 2.20
L/W = 1.042	T/W = 0.535
U/W = 0.514	P/W = 0.388
C/W = 0.155	V/W ³ = 0.205

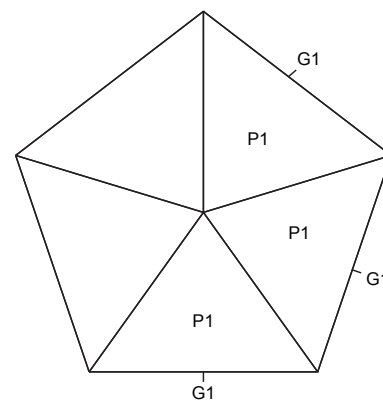
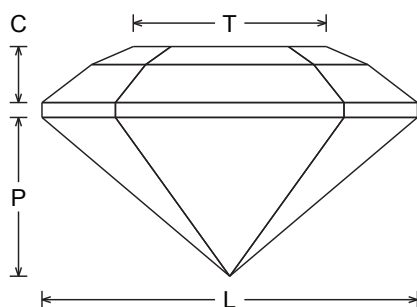
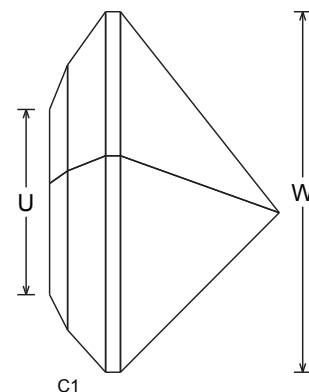
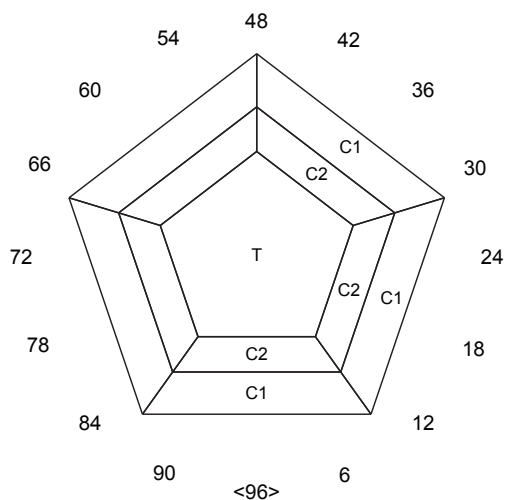

Pavilion *A = RI 1.54 to 2.20

Facets	A	Index	Instructions
P1	44.87°	96-19-38-58-77	Form FCP
G1	90.00°	96-19-38-58-77	Set stone size. Establish a level girdle

Crown *A = RI 1.54 to 2.20

Facets	A	Index	Instructions
C1	42.00°	96-19-38-58-77	Establish girdle width
C2	27.00°	96-19-38-58-77	Float in tier as shown in the diagram
T	0.00°	Table	Float in table as shown in the diagram

Please visit facetingdesigns.com for more faceting designs by Andrew Brown

RI = 1.54

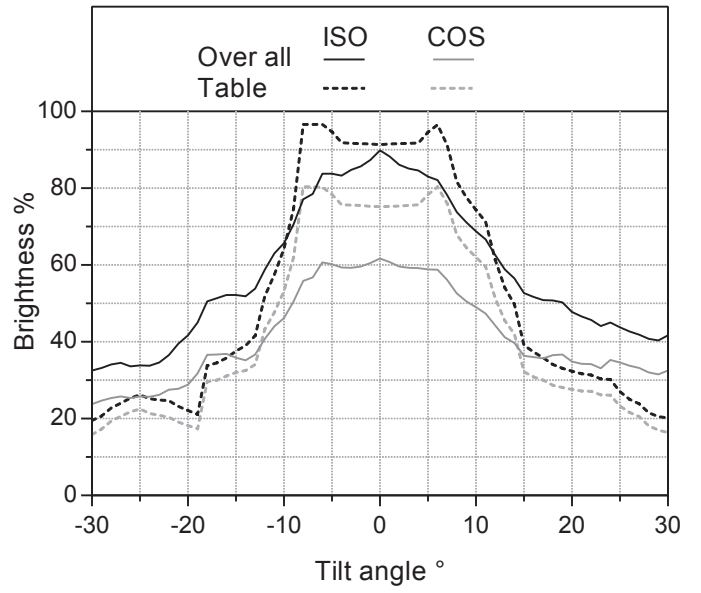

RI = 1.76

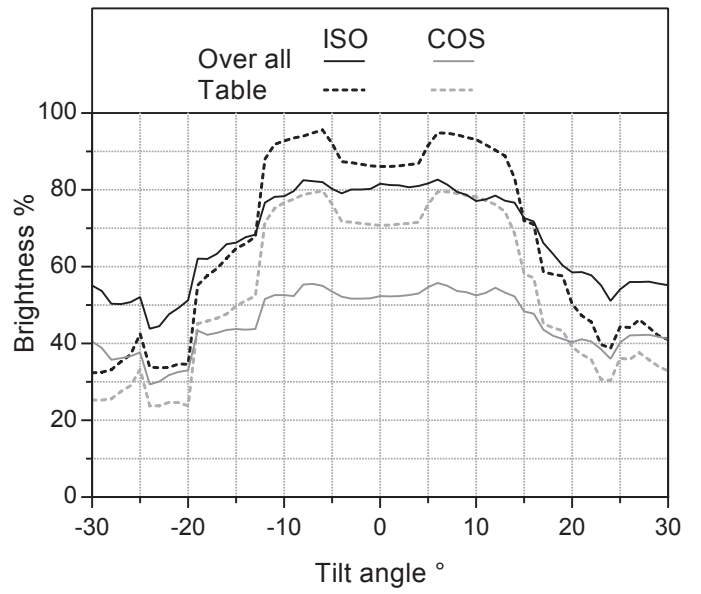

RI = 2.16

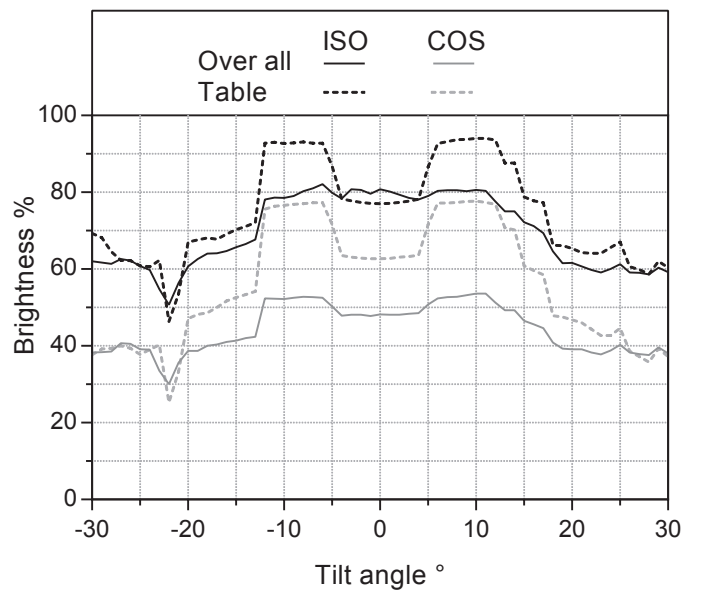

3. Trillion

Design name: Trioptic Blast

Number of facets: 37

Description:

The trillion shape, sometimes referred to as trillian, trilliant, or trielle, is a triangular cut that has many variations with curved or uncurved sides. Origins of trillion-cut diamonds can be traced to the Asscher brothers, based in Amsterdam, who cut triangular diamonds in the 18th century. This design may have a low facet-count but has excellent performance. I find that 3-fold symmetry generates exceptional performance and scintillation. Note how cut corners have been incorporated into the design for easy mounting.

Notes:

- Take care cutting the fine P2 facets as they will be used to set the girdle outline, forming the cut corners.
- Check the crown C3 facets frequently when cutting to make sure they meet C1, C2 on both ends evenly. Adjust and take notes if needed.

Trioptic Blast

AIB253

© Andrew Brown
July 2022

Design Information	
Pavilion facets	15
Girdle facets	9
Crown facets	12+1
Total facets	37
Index gear	96
Symmetry	3-fold mirror image
RI range	1.54 to 2.40
RI diagram	1.54 to 1.90
L/W = 1.089	T/W = 0.679
U/W = 0.588	P/W = 0.475
C/W = 0.149	V/W ³ = 0.213

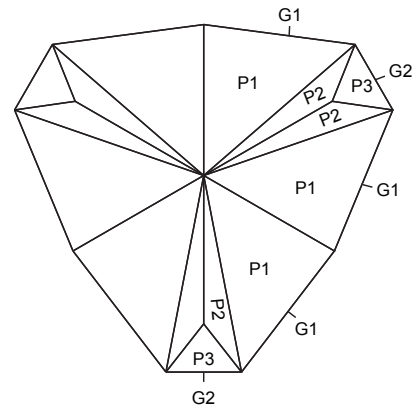
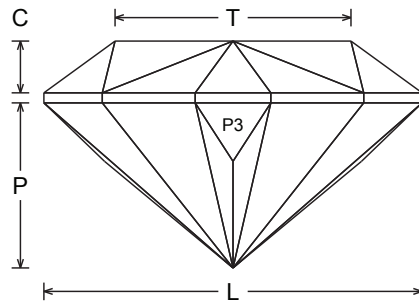
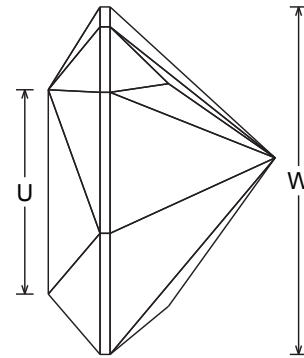
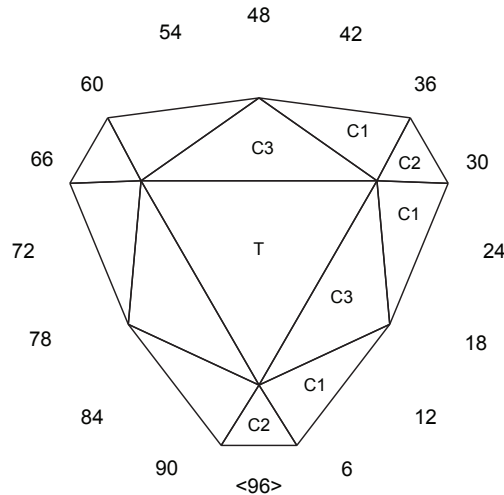

Pavilion *A = RI 1.54 to 1.90 B = RI 1.90 to 2.40

Facets	A	B	Index	Instructions
P1	47.80°	46.90°	14-18-46-50-78-82	Form FCP
P2	43.70°	42.80°	11-21-43-53-75-85	Meet FCP [Cut slowly]
G1	90.00°	90.00°	14-18-46-50-78-82	Set stone size. Establish a level girdle
G2	90.00°	90.00°	96-32-64	Meet G1, P1, P2 [Cut slowly]
P3	50.50°	50.50°	96-32-64	Meet G1, G2, P1, P2. Maintain a level girdle [Cut slowly]

Crown A = RI 1.54 to 1.90 B = RI 1.90 to 2.40

Facets	A	B	Index	Instructions
C1	37.80°	37.80°	14-18-46-50-78-82	Establish girdle width
C2	40.62°	40.62°	96-32-64	Meet G1, G2, C1. Maintain girdle width
C3	32.00°	32.00°	16-48-80	Meet G1, C1 & C1, C2
T	0.00°	0.00°	Table	Meet C1, C2, C3

Please visit facetingdesigns.com for more faceting designs by Andrew Brown

RI = 1.54

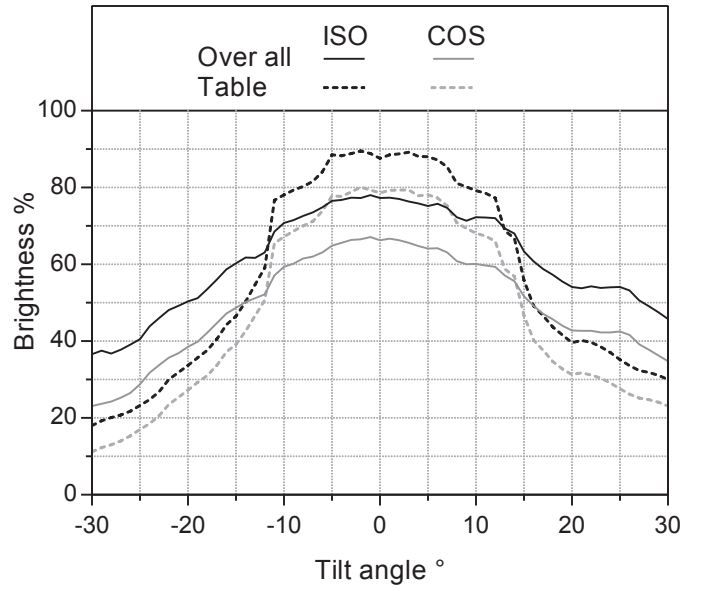

RI = 1.76

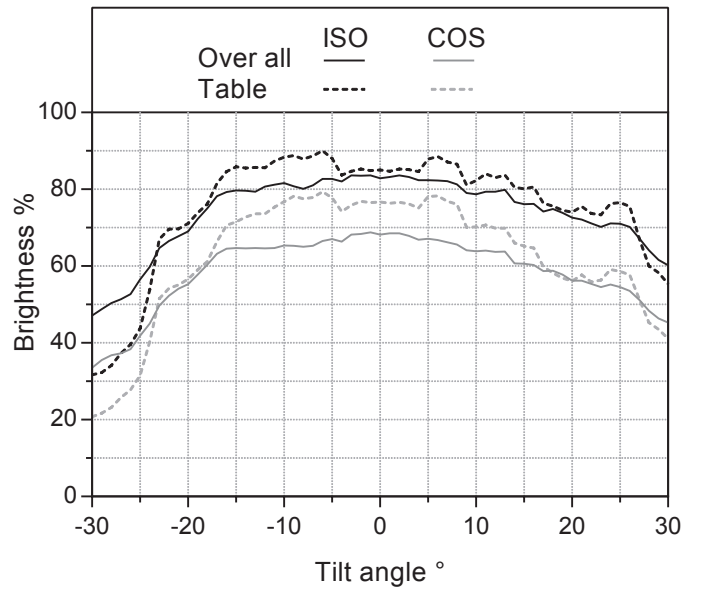

RI = 2.16

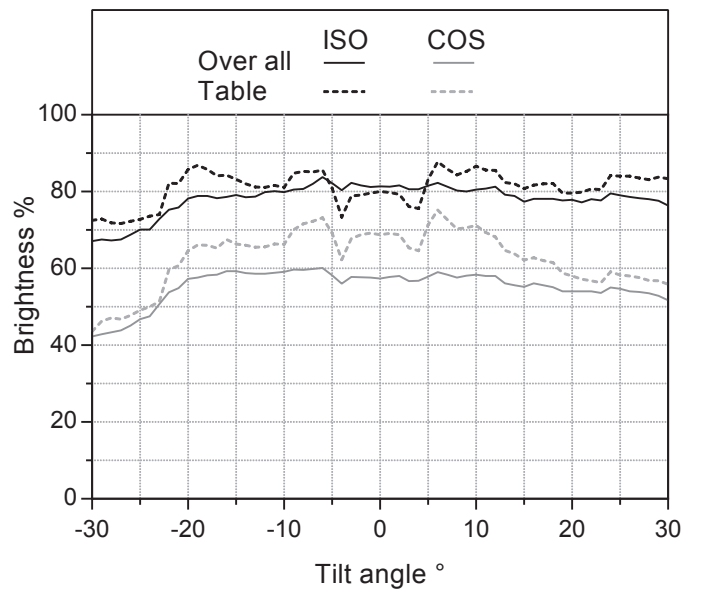

4. Marquise

Design name: Easy Cut Marquise

Number of facets: 33

Description:

The marquise design originates from the 18th century when King Louis XV of France ordered a jeweler to create a diamond cut that would represent the lips of his lover, Jean Antoinette Poisson Marchioness Madame de Pompadour. The marquise is also commonly referred to as a navette, which means small ship in French. Even though this design has a low-facet count, I have been able to match the crown and pavilion shapes to produce excellent performance.

Notes:

- It is important to get the transfer spot on. With the long thin stone, errors will be noticeable on the ends of the stone. If the transfer is out, it will be hard to get the girdle level and to form nice meet points with the table at C1, C3.
- Polishing the long table may prove a challenge for the beginner. Take your time. You will most likely need to use your machine's "cheater" or fine adjustment to align the table correctly.

Easy Cut Marquise

AIB254

© Andrew Brown
July 2022

Design Information	
Pavilion facets	12
Girdle facets	8
Crown facets	12+1
Total facets	33
Index gear	96
Symmetry	2-fold mirror image
RI range	1.54 to 2.00
RI diagram	1.54 to 1.65
L/W = 2.133	T/W = 1.528
U/W = 0.519	P/W = 0.460
C/W = 0.173	V/W ³ = 0.497

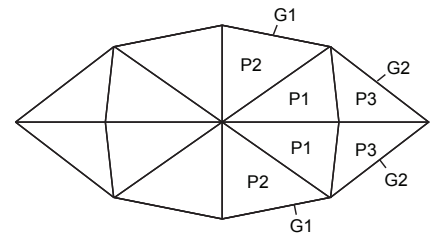
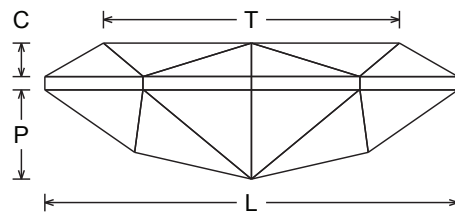
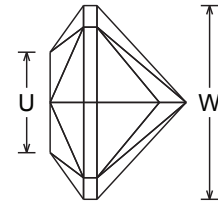
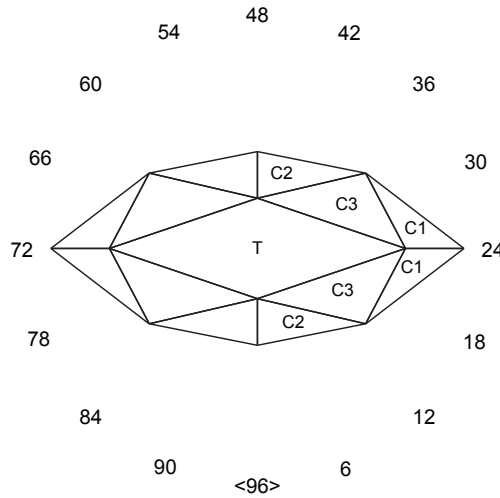

Pavilion *A = RI 1.54 to 1.65 B = RI 1.65 to 1.85 C = RI 1.85 to 2.00

Facets	A	B	C	Index	Instructions
P1	41.50°	40.19°	38.81°	04-44-52-92	Form FCP
P2	43.17°	41.86°	40.46°	03-45-51-93	Meet FCP
G1	90.00°	90.00°	90.00°	03-45-51-93	Set stone size. Establish a level girdle
G2	90.00°	90.00°	90.00°	10-38-58-86	Meet G1, P1, P2
P3	48.79°	47.48°	46.08°	10-38-58-86	Meet G1, G2, P1, P2. Maintain a level girdle

Crown *A = RI 1.54 to 1.65 B = RI 1.65 to 1.85 C = RI 1.85 to 2.00

Facets	A	B	C	Index	Instructions
C1	43.23°	43.23°	43.23°	10-38-58-86	Establish girdle width
C2	36.14°	36.14°	36.14°	03-45-51-93	Meet G1, G2, C1. Maintain girdle width
C3	29.70°	29.70°	29.70°	05-43-53-91	Meet G1, G2, C1, C2
T	0.00°	0.00°	0.00°	Table	Meet C2, C3, C1, C3

Please visit facetingdesigns.com for more faceting designs by Andrew Brown

RI = 1.54

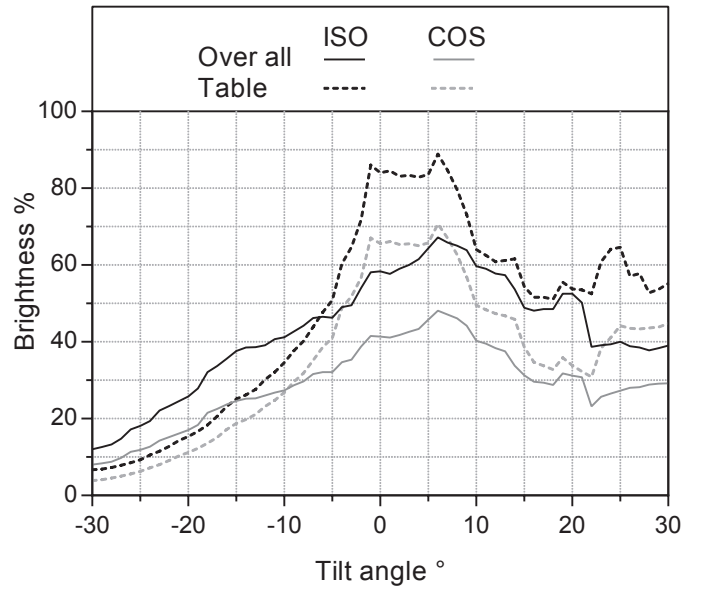
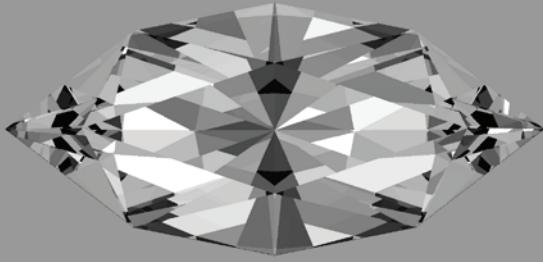

RI = 1.76

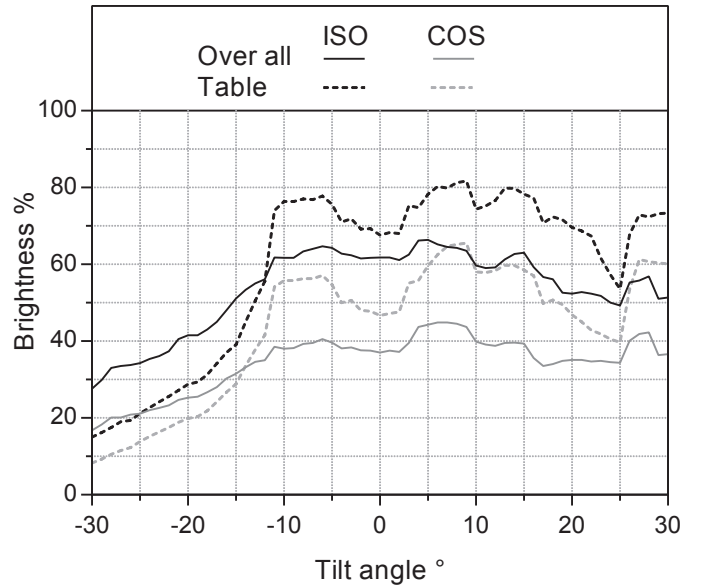
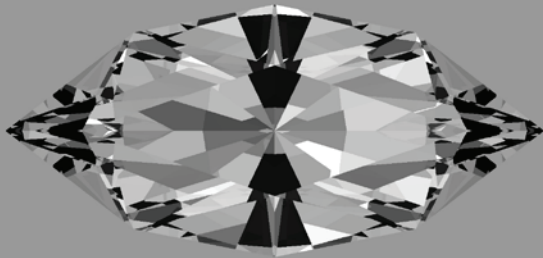

RI = 1.95

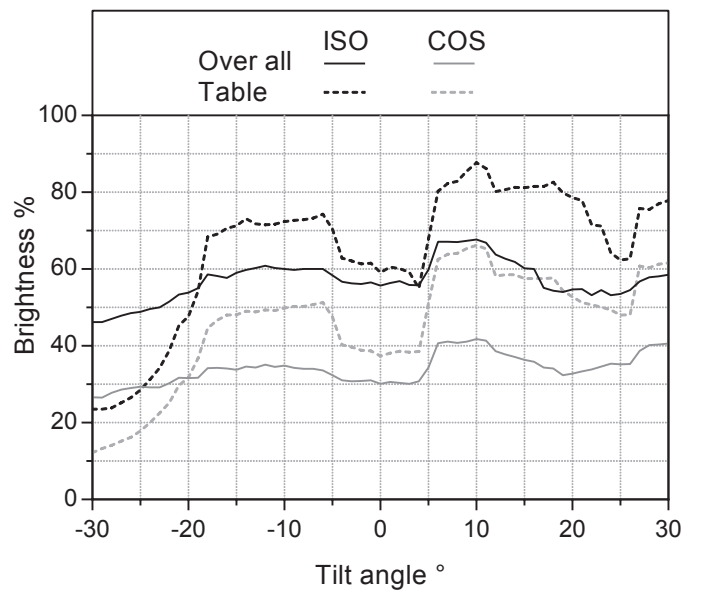
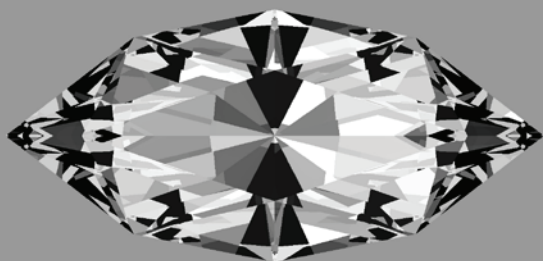

5. Square

Design name: Little Princess

Number of facets: 49

Description:

This square design is a simplified princess cut. Princess-cut diamonds are the second most popular shape after round brilliants. Origins of the princess cut can be traced back to Englishman Arpad Nagy in the 1960's. The crown shape has been matched to the pavilion to create excellent performance even at lower refractive indexes.

Notes:

- Take care cutting P1 and G1 to form the base of this stone, as it will really help to create a level girdle when cutting P2.
- When cutting the crown, watch out for tiers C2 and C3. Note they are both the same index, which may be a bit confusing. They are about 5 degrees different so it shouldn't be too tricky to cut. Take your time cutting C3 so you can see what is happening and how it will meet C1, C2.

Little Princess

AIB255

© Andrew Brown
July 2022

Design Information	
Pavilion facets	20
Girdle facets	4
Crown facets	24+1
Total facets	49
Index gear	96
Symmetry	4-fold mirror image
RI range	1.54 to 2.20
L/W = 1.000	T/W = 0.490
U/W = 0.490	P/W = 0.488
C/W = 0.169	V/W ³ = 0.312

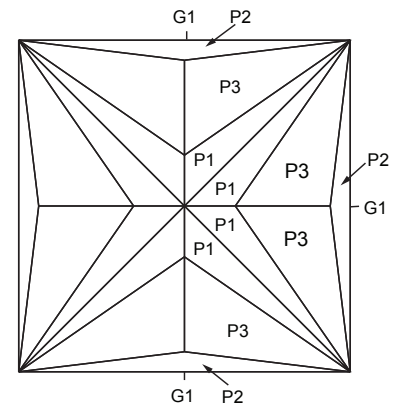
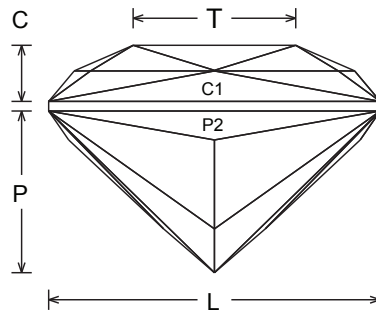
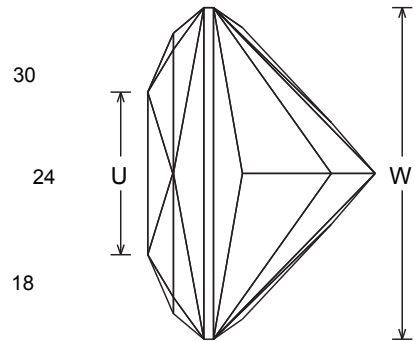
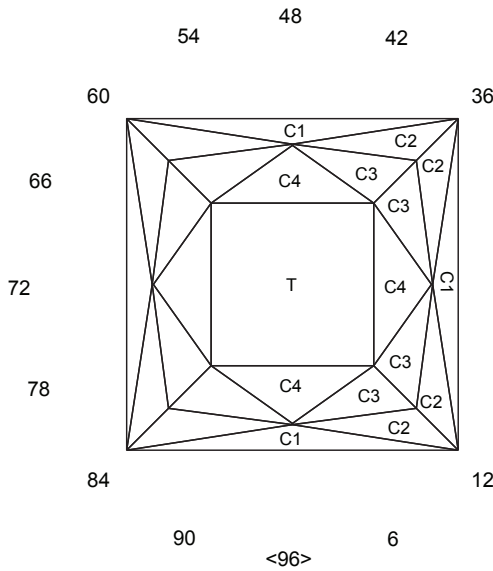

Pavilion *A = RI 1.54 to 2.20

Facets	A	Index	Instructions
P1	41.00°	02-22-26-46-50-70-74-94	Form FCP
G1	90.00°	96-24-48-72	Set stone size
P2	55.33°	96-24-48-72	Meet G1, P1. Establish a level girdle
P3	43.19°	01-23-25-47-49-71-73-95	Meet G1, P1, P2

Crown *A = RI 1.54 to 2.20

Facets	A	Index	Instructions
C1	50.00°	96-24-48-72	Establish girdle width
C2	32.95°	02-22-26-46-50-70-74-94	Meet G1, C1
C3	28.22°	02-22-26-46-50-70-74-94	Meet C1, C2
C4	23.44°	96-24-48-72	Meet C1, C2, C3
T	0.00°	Table	Meet C3, C4

Please visit facetingdesigns.com for more faceting designs by Andrew Brown

RI = 1.54

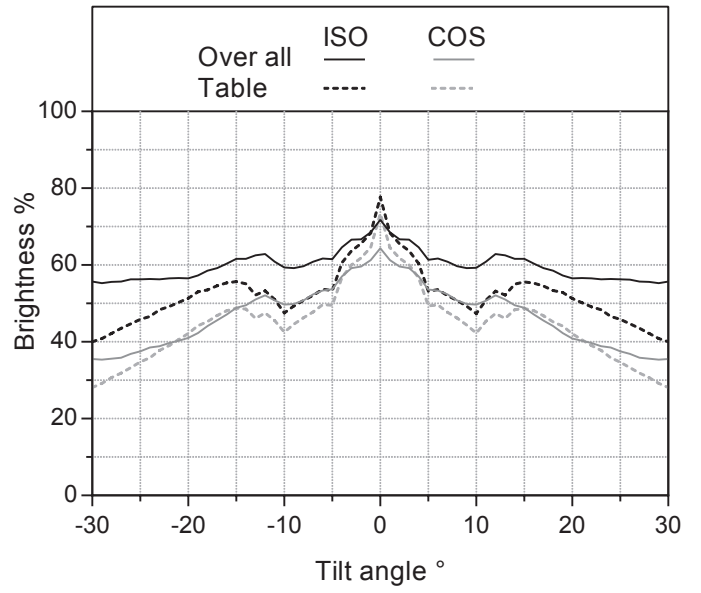
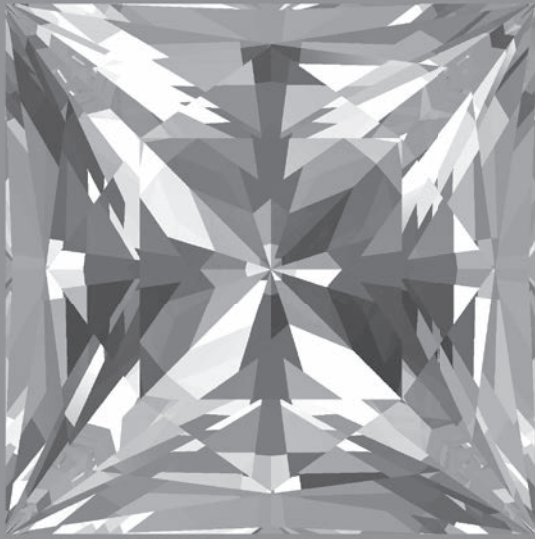

RI = 1.76

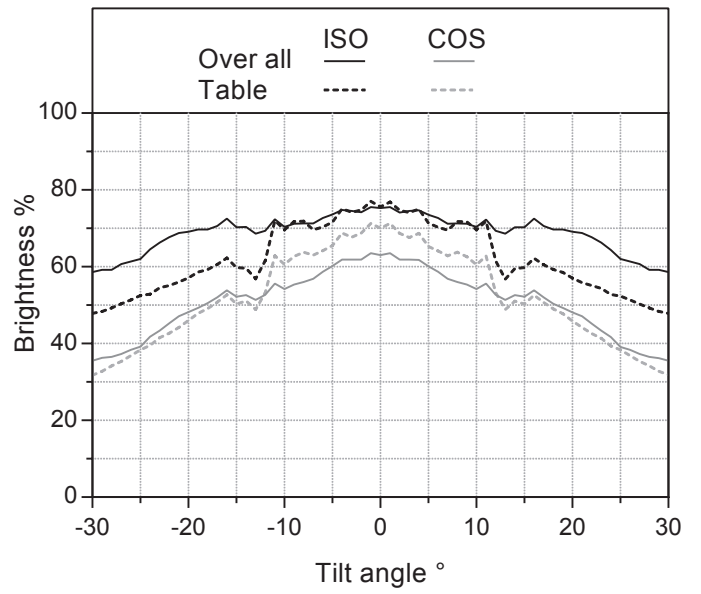

RI = 2.16

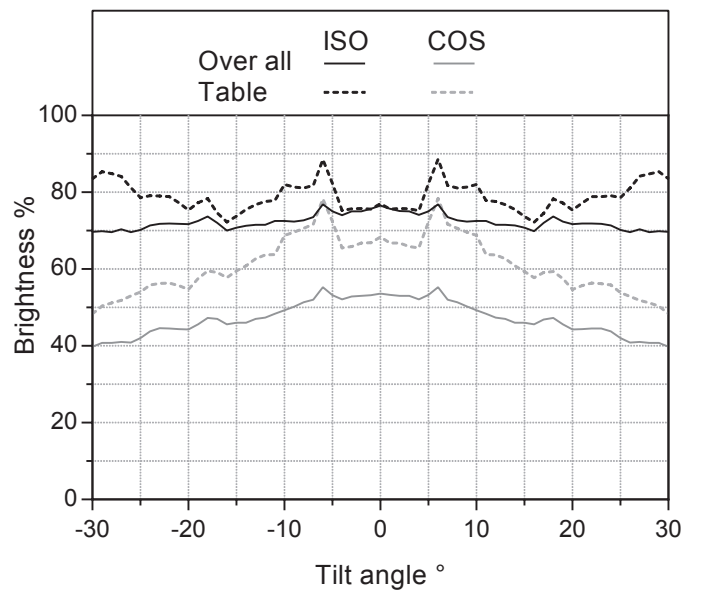

6. Pear

Design name: Seven Star Pear

Number of facets: 36

Description:

The origin of the pear shape can be traced back to Flemish gem cutter Lodewyk van Berquem, in the late 1400s. This pear design uses imperfect 7-fold symmetry on the pavilion tier P1 to create scintillation and performance. The stone shape is then set and two barion-like tiers (P2, P3) are used to level the girdle when cutting the pavilion.

Notes:

- Take your time cutting P3 to create a level girdle.
- Hitting all the meet points on the table may be challenging. Take care so you don't over-cut any. If some of the meet points are off a lot, consider going back and gently adjusting (most likely some of the C1 facets) to form the meet points after polishing the table.

Seven Star Pear

AIB256

© Andrew Brown
July 2022

Design Information	
Pavilion facets	14
Girdle facets	7
Crown facets	14+1
Total facets	36
Index gear	96
Symmetry	1-fold mirror image
RI range	1.54 to 2.40
L/W = 1.073	T/W = 0.699
U/W = 0.596	P/W = 0.505
C/W = 0.138	V/W ³ = 0.249

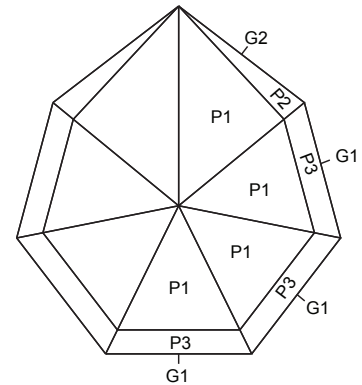
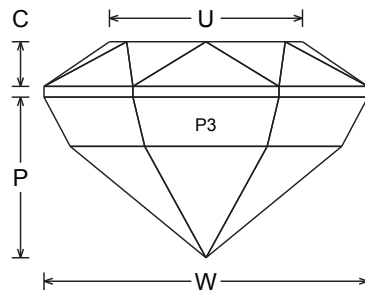
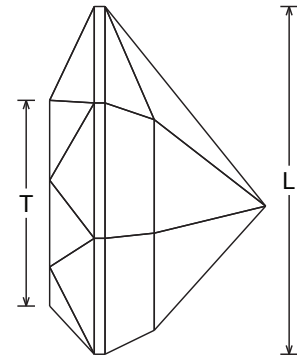
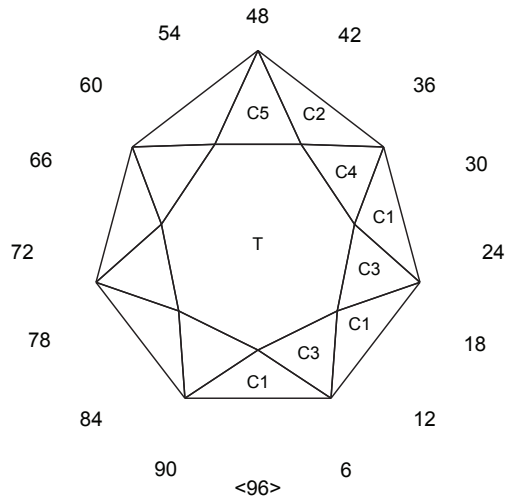

Pavilion *A = RI 1.54 to 2.40

Facets	A	Index	Instructions
P1	42.40°	96-14-28-41-55-68-82	Form FCP
G1	90.00°	96-14-28-68-82	Set stone size
G2	90.00°	38-58	Meet G1, P1
P2	62.92°	38-58	Meet G2, P1. Establish a level girdle
P3	64.44°	96-14-28-68-82	Meet G1, G2, P1, P2 & P1, P2 on indexes 28 and 68 to set tier depth. Cut remaining facets to the same depth. Maintain a level girdle

Crown *A = RI 1.54 to 2.40

Facets	A	Index	Instructions
C1	42.80°	96-14-28-68-82	Establish girdle width
C2	42.80°	38-58	Meet G1, G2, C1. Maintain girdle width
C3	30.58°	07-21-75-89	Meet G1, C1
C4	33.59°	33-63	Meet G1, G2, C1, C2
C5	25.44°	48	Meet G2, C2
T	0.00°	Table	Meet C1, C3 & C1, C3, C4 & C2, C4, C5

Please visit facetingdesigns.com for more faceting designs by Andrew Brown

RI = 1.54

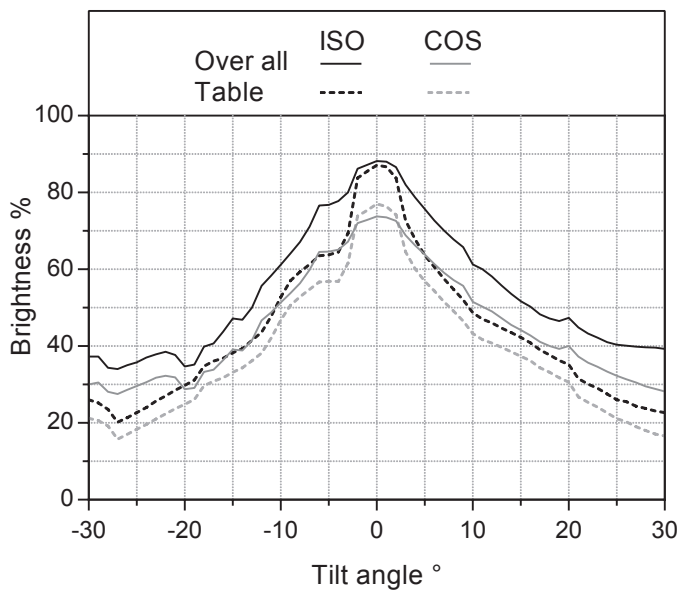

RI = 1.76

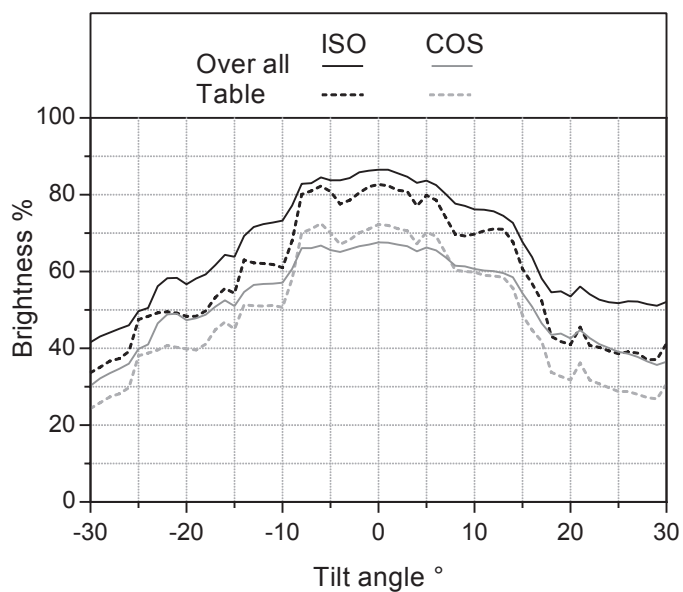

RI = 2.16

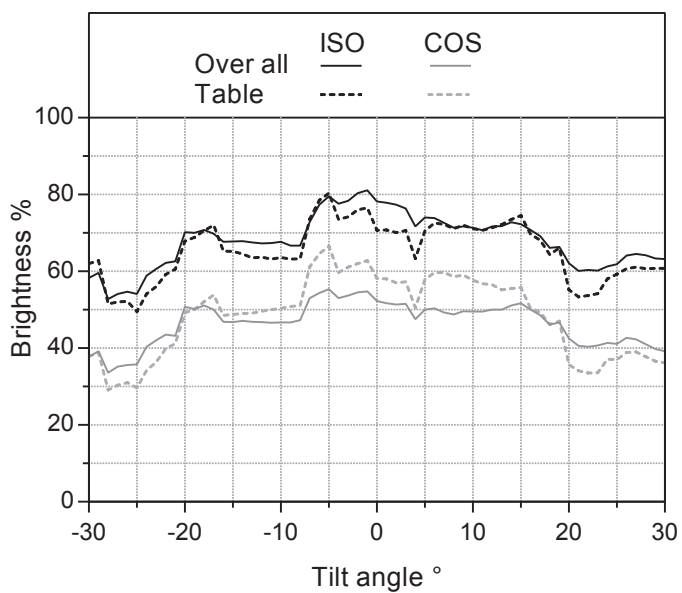

7. Decagon

Design name: DecaCheck Two

Number of facets: 36

Description:

The word decagon is from the Greek “deka”, and “goní.” This is my second DecaCheck design. The first can be found in my book, “A Collection of My Best Gemstone Faceting Designs, Volume 3.” This one is easier to cut and uses the 96 index. Performance and scintillation are generated from the pavilion using imperfect 5-fold odd symmetry. I have optimized the crown so you don’t need to cut any low angles that checker crowns can often have. This is a great design for a beginner’s first checker crown.

Notes:

- Take care cutting the G1 facets as you’ll notice in the diagram, only half of them will form a level girdle with P1. After you have cut G1, facet tier P2 then finishes the level girdle.
- The crown may look tricky to cut, but it will be a lot easier than you expect as it only has a small number of facets.

DecaCheck Two

AIB257

© Andrew Brown
July 2022

Design Information	
Pavilion facets	10
Girdle facets	10
Crown facets	16
Total facets	36
Index gear	96
Symmetry	1-fold mirror image
RI range	1.54 to 2.20
L/W = 1.056	P/W = 0.476
C/W = 0.217	V/W ³ = 0.241

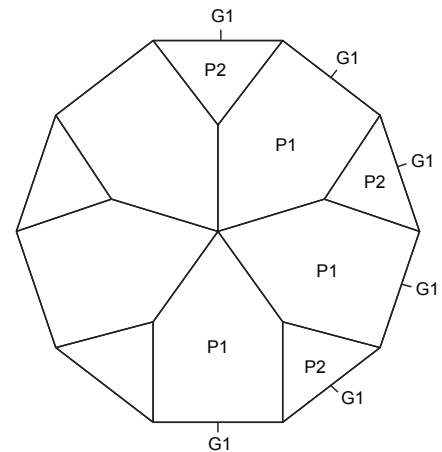
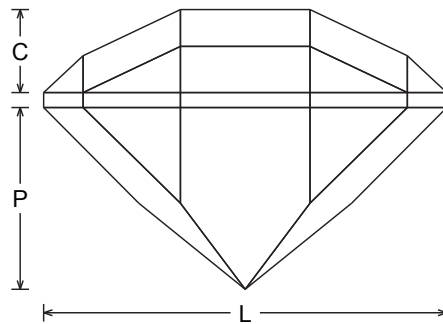
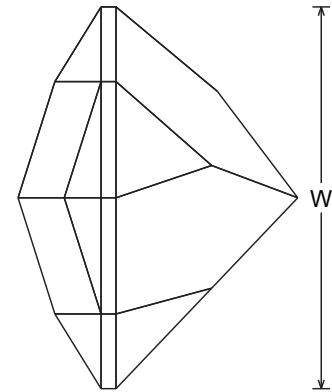
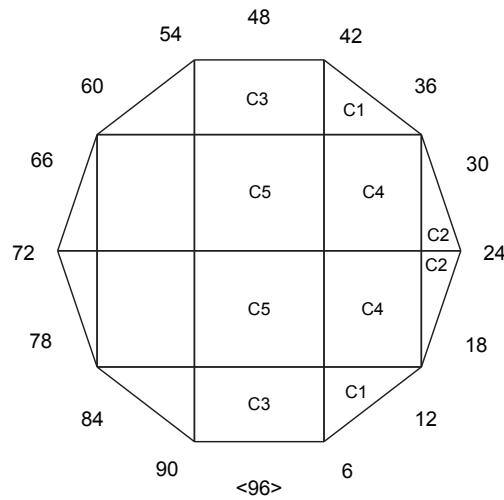

Pavilion *A = RI 1.54 to 2.30

Facets	A	Index	Instructions
P1	43.60°	96-19-38-58-77	Form FCP
G1	90.00°	96-10-19-29-38-48-58-67-77-86	Establish a level girdle on corresponding P1 indexes to set tier depth. Cut remaining facets to the same depth
P2	50.20°	10-29-48-67-86	Meet G1, P1. Maintain a level girdle

Crown *A = RI 1.54 to 2.30

Facets	A	Index	Instructions
C1	37.93°	10-38-58-86	Establish girdle width
C2	44.60°	19-29-67-77	Meet G1, C1. Maintain girdle width
C3	31.72°	96-48	Meet G1, C1. Maintain girdle width
C4	29.70°	15-33-63-81	Meet G1, C1, C2
C5	17.59°	96-48	Meet C1, C3, C4

Please visit facetingdesigns.com for more faceting designs by Andrew Brown

RI = 1.54

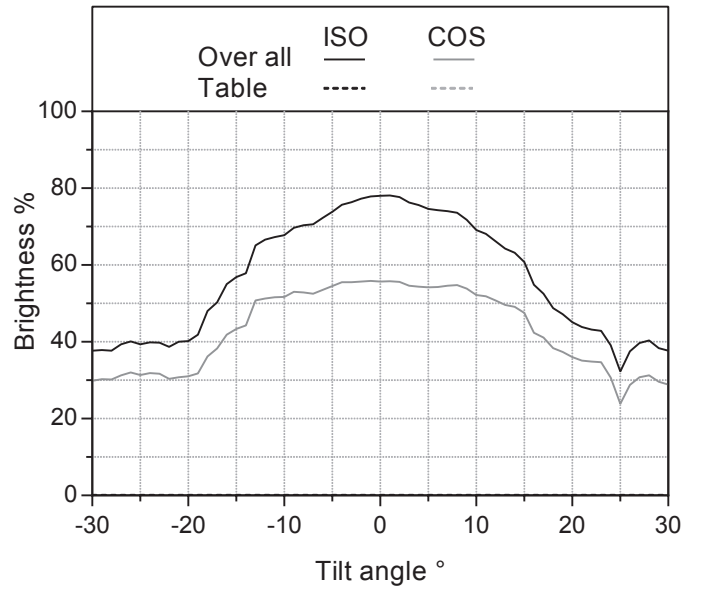
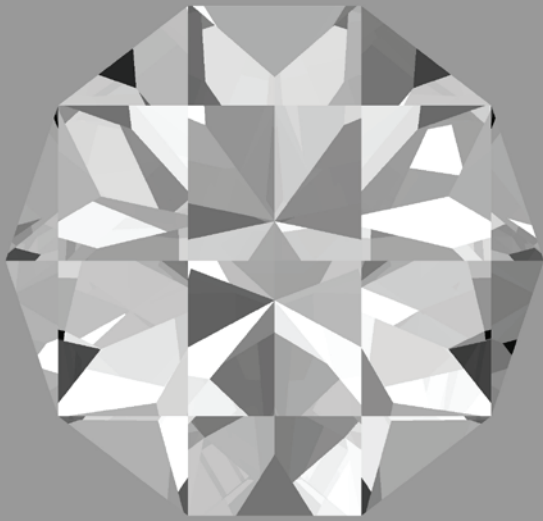

RI = 1.76

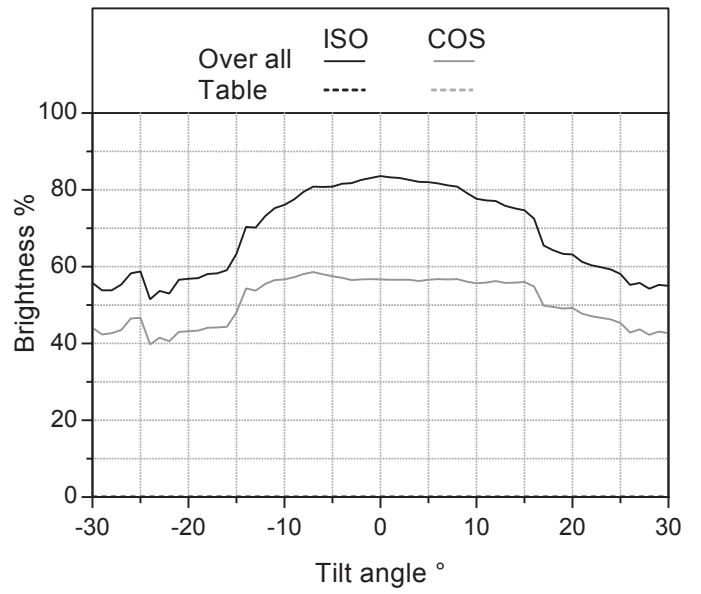
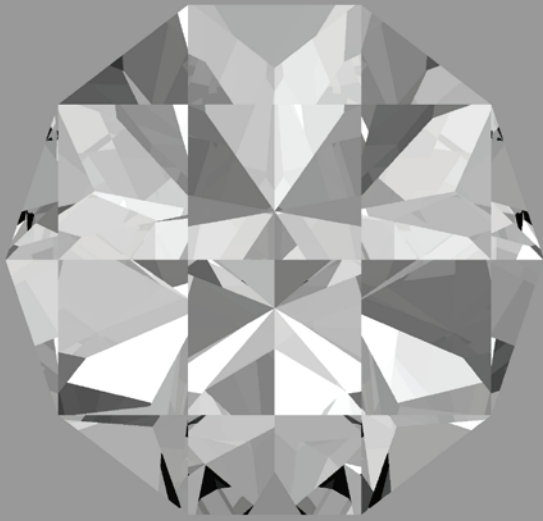

RI = 2.16

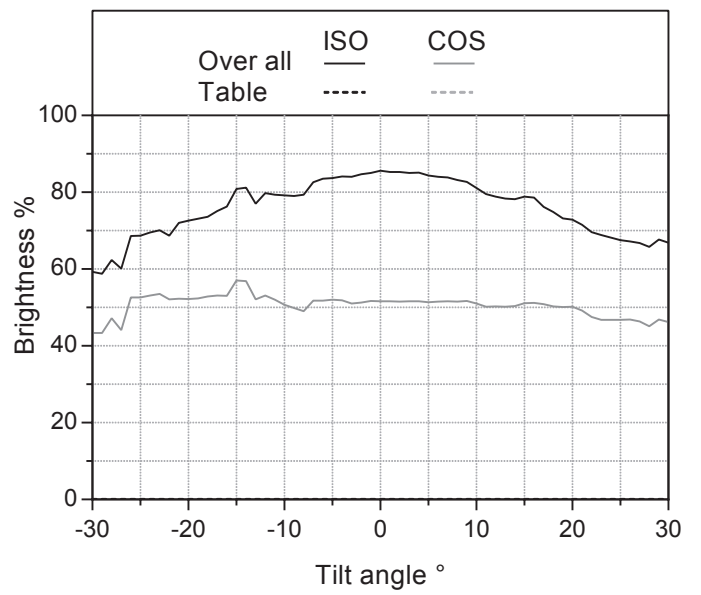

8. Shield/Heart

Design name: Shield of the Heart

Number of facets: 31

Description:

I couldn't decide if this was a shield or a heart, hence the name. The pavilion uses 3-fold symmetry on the P1 tier to create outstanding scintillation and performance. The girdle shape is then set and the beginner will then see how barion facets are used to level the girdle on tiers P3 and P4. Barion facets are half-moon-like facets, first used by Basil Watermeyer in 1971.

Notes:

- Hopefully, with the skills you have acquired cutting the preceding designs, this one should be straightforward.

Shield Of The Heart

AIB258

© Andrew Brown
July 2022

Design Information	
Pavilion facets	13
Girdle facets	7
Crown facets	10+1
Total facets	31
Index gear	96
Symmetry	1-fold mirror image
RI range	1.54 to 2.20
L/W = 1.032	T/W = 0.500
U/W = 0.433	P/W = 0.454
C/W = 0.161	V/W ³ = 0.211

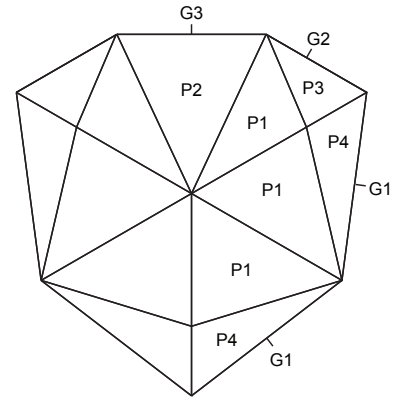
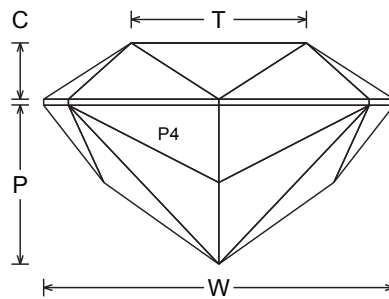
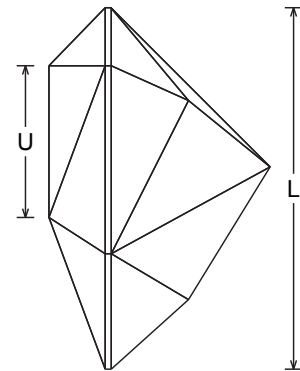
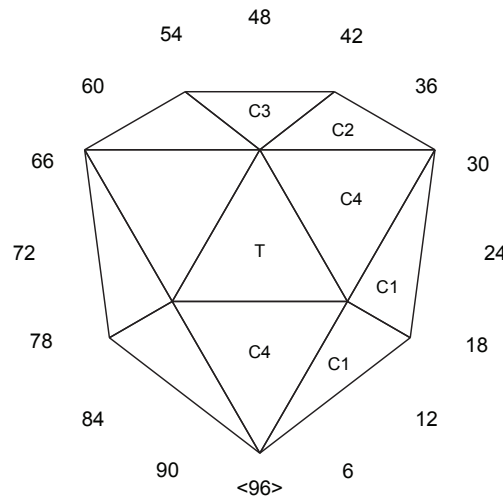

Pavilion

*A = RI 1.54 to 2.30

Facets	A	Index	Instructions
P1	43.00°	13-19-45-51-77-83	Form FCP
P2	45.00°	48	Meet FCP
G1	90.00°	10-22-74-86	Set stone size
G2	90.00°	40-56	Meet G1, P1
G3	90.00°	48	Meet G2, P1, P2. Establish a level girdle
P3	52.06°	40-56	Meet G2, G3, P1, P2. Maintain a level girdle
P4	54.47°	10-22-74-86	Meet G1, P1. Maintain a level girdle

Crown

*A = RI 1.54 to 2.30

Facets	A	Index	Instructions
C1	40.00°	10-22-74-86	Establish girdle width
C2	32.71°	40-56	Meet G1, G2, C1. Maintain girdle width
C3	44.10°	48	Meet G2, G3, C2. Maintain girdle width
C4	20.34°	96-32-64	Meet G1, C1 on index 96 Meet G1, G2, C1, C2 on indexes 32 and 64
T	0.00°	Table	Meet C1, C4 & C2, C3, C4

Please visit facetingdesigns.com for more faceting designs by Andrew Brown

RI = 1.54

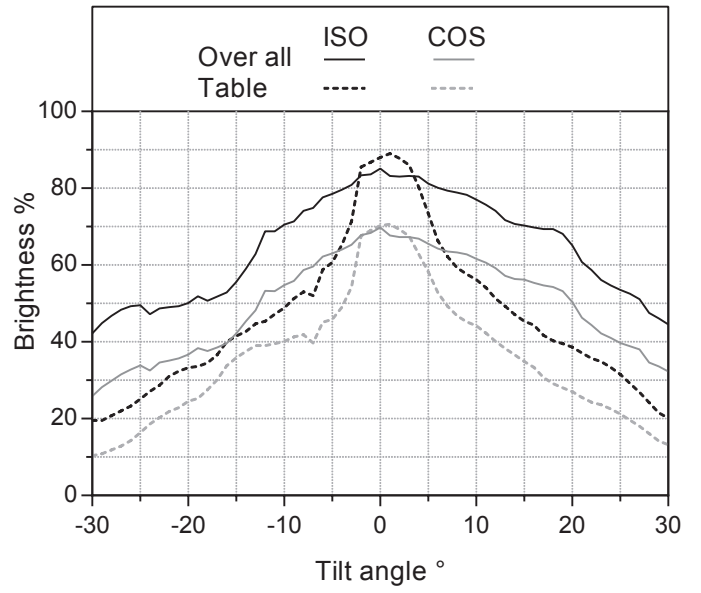

RI = 1.76

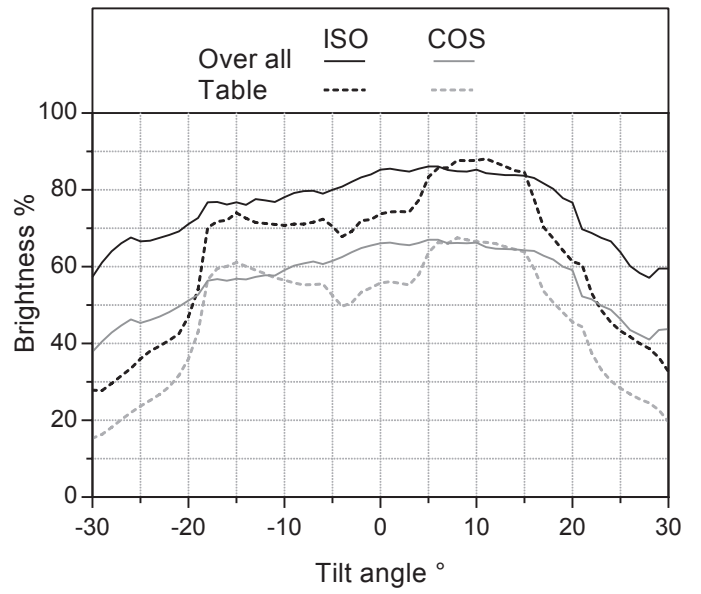

RI = 2.16

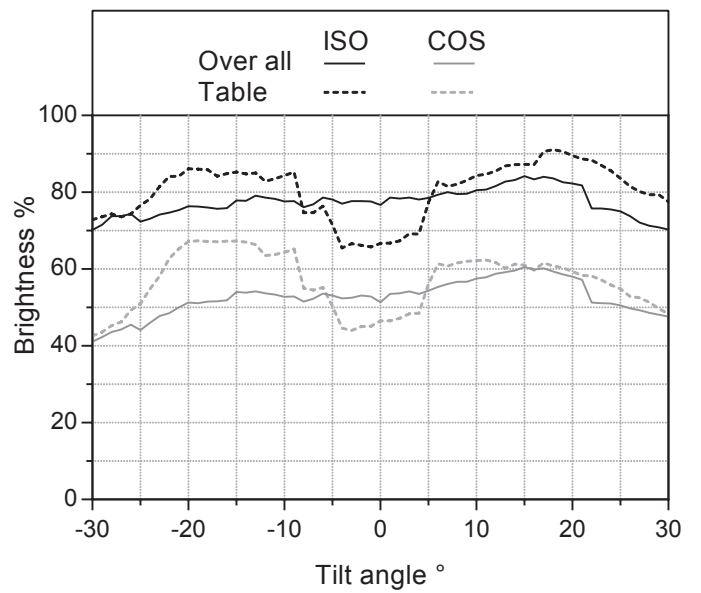

9. Oval

Design name: Beginner Oval 1.40

Number of facets: 47

Description:

Even though this oval is very simple, it will take longer to cut than previous designs in this book due to the larger number of facet tiers.

Notes:

- Be sure to follow the sequence of pavilion cutting instructions forming the stone girdle outline correctly.
- Adjust the tier C5 angle slightly if you are having trouble meeting the meet points.

Beginner Oval 1.40

AIB259

© Andrew Brown
July 2022

Design Information	
Pavilion facets	16
Girdle facets	12
Crown facets	18+1
Total facets	47
Index gear	96
Symmetry	2-fold mirror image
RI range	1.54 to 1.90
L/W = 1.393	T/W = 0.770
U/W = 0.585	P/W = 0.457
C/W = 0.186	V/W ³ = 0.332

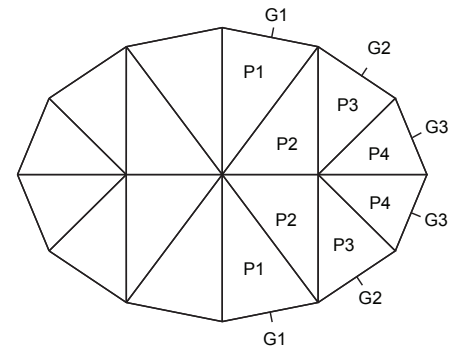
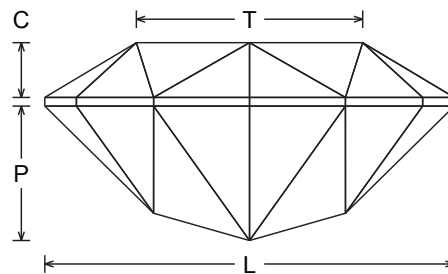
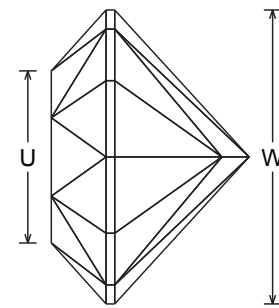
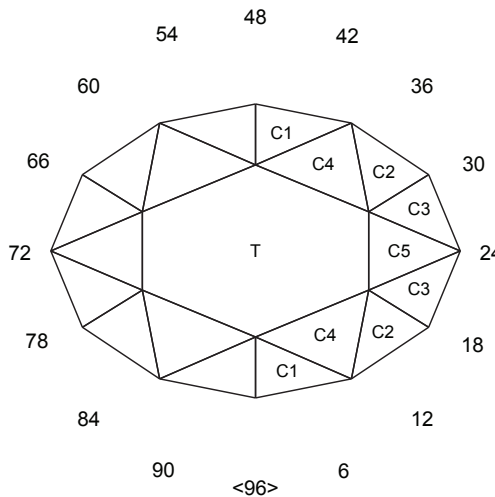

Pavilion

*A = RI 1.54 to 1.90

Facets	A	Index	Instructions
P1	43.00°	03-45-51-93	Form FCP
P2	41.50°	05-43-53-91	Meet FCP
G1	90.00°	03-45-51-93	Set stone size. Establish a level girdle
G2	90.00°	09-39-57-87	Meet G1, P1, P2
P3	45.22°	09-39-57-87	Meet G1, G2, P1, P2. Maintain a level girdle
P4	46.83°	18-30-66-78	Meet P2, P3
G3	90.00°	18-30-66-78	Meet G2, P3, P4. Maintain a level girdle

Crown

*A = RI 1.54 to 1.90

Facets	A	Index	Instructions
C1	42.50°	03-45-51-93	Establish girdle width
C2	40.47°	09-39-57-87	Meet G1, G2, C1. Maintain girdle width
C3	38.19°	18-30-66-78	Meet G2, G3, C2. Maintain a level girdle
C4	36.00°	06-42-54-90	Meet G1, G2, C1, C2
C5	30.88°	24-72	Meet G3, C3 & C2, C3, C4
T	0.00°	Table	Meet C1, C4 & C2, C3, C4, C5

Please visit facetingdesigns.com for more faceting designs by Andrew Brown

RI = 1.54

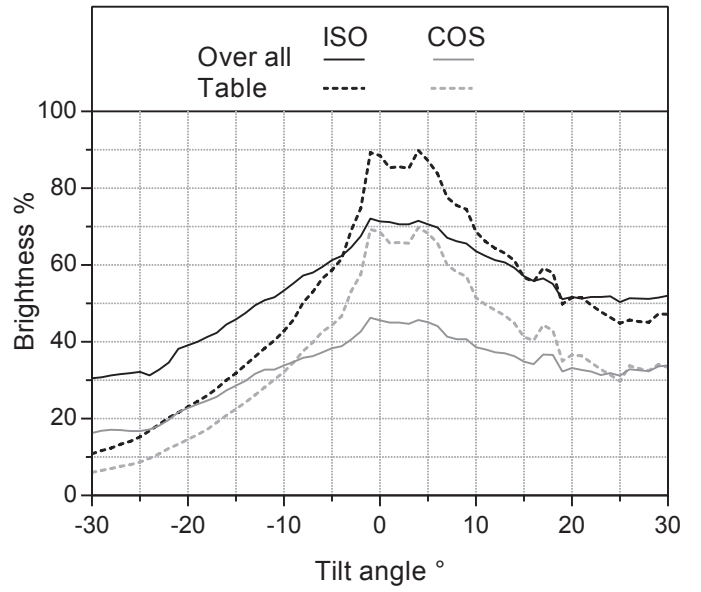
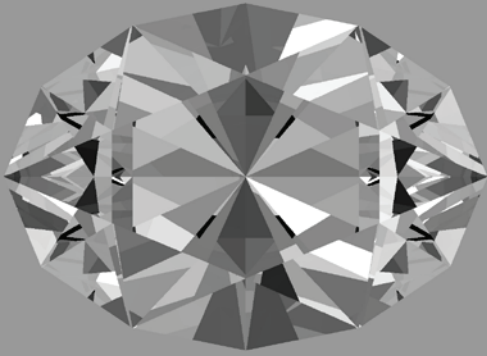

RI = 1.76

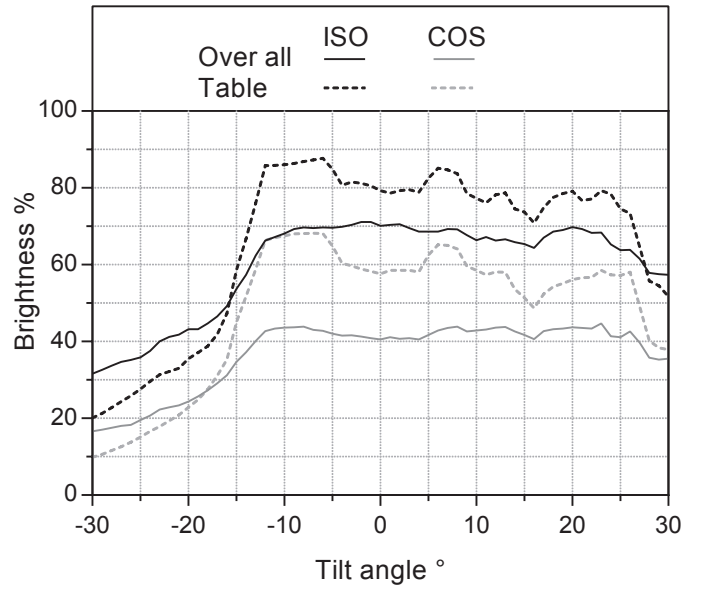
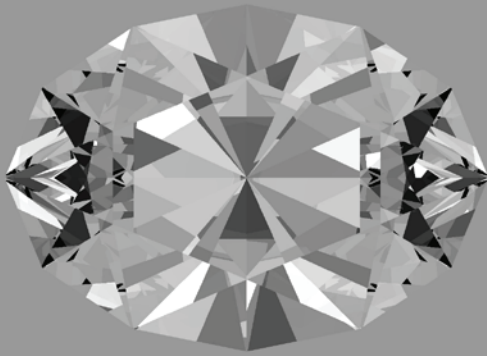

RI = 1.90

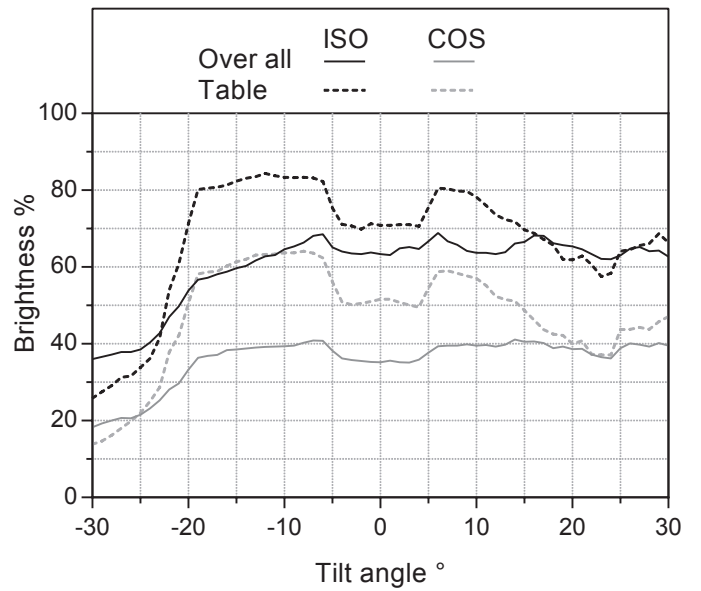
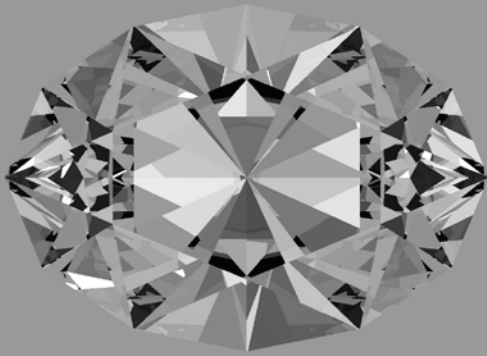

10. Round

Design name: Six Star Brilliant

Number of facets: 67

Description:

This design produces an excellent round brilliant. Forget the SRB and give this a try. The design combines 6-fold and 3-fold symmetry on an 18-sided round. The crown is very similar to my design, Brilliant Six, found in "A collection of my best Gemstone Faceting Designs Volume 3". The design uses a simpler pavilion but still has exceptional performance especially in low-mid RI minerals like quartz, topaz, and sapphire.

Notes:

- Take care cutting the G1 facets as you'll notice in the diagram, only half of them will form a level girdle with P1. After you have cut G1, facet tier P2 finishes the level girdle.

Six Star Brilliant

AIB260

© Andrew Brown
July 2022

Design Information	
Pavilion facets	18
Girdle facets	18
Crown facets	30+1
Total facets	67
Index gear	96
Symmetry	3-fold mirror image
RI range	1.54 to 2.40
L/W = 1.020	T/W = 0.461
U/W = 0.399	P/W = 0.432
C/W = 0.208	V/W ³ = 0.247

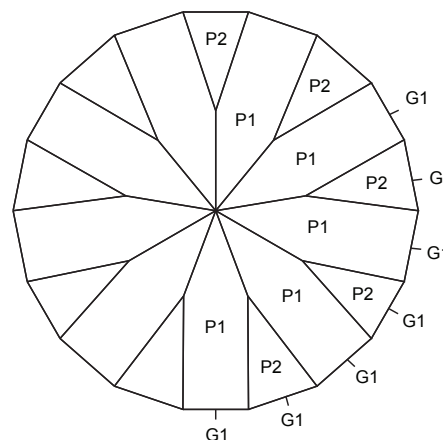
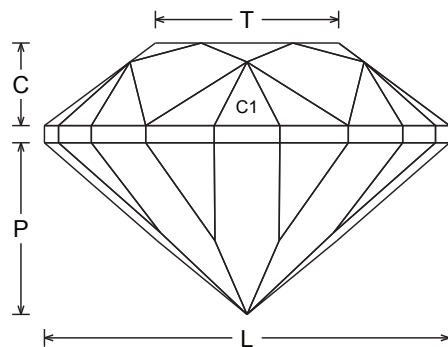
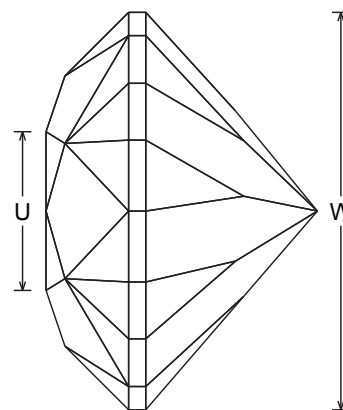
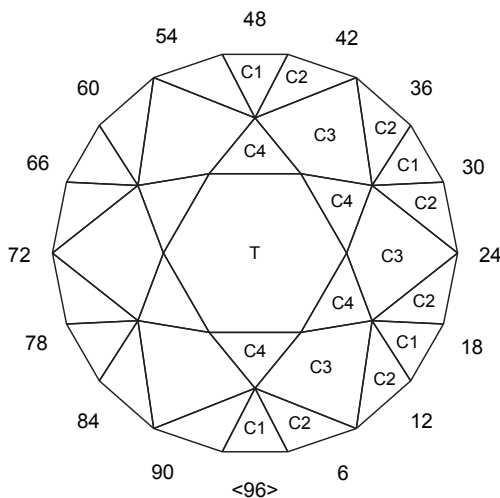

Pavilion *A = RI 1.54 to 2.40

Facets	A	Index	Instructions
P1	40.82°	96-11-21-32-43-53-64-75-85	Form FCP
G1	90.00°	96-05-11-16-21-27-32-37-43-48-53-59-64-69-75-80-85-91	Set stone size. Establish a level girdle on corresponding P1 indexes
P2	42.31°	05-16-27-37-48-59-69-80-91	Meet G1, P1. Maintain a level girdle

Crown *A = RI 1.54 to 2.40

Facets	A	Index	Instructions
C1	45.06°	96-16-32-48-64-80	Establish girdle width
C2	42.00°	05-11-21-27-37-43-53-59-69-75-85-91	Meet G1, P1, P2
C3	36.66°	08-24-40-56-72-88	Meet G1, G2, C2 & C1, C2
C4	18.74°	96-16-32-48-64-80	Meet C1, C2, C3
T	0.00°	Table	Meet C3, C4

Please visit facetingdesigns.com for more faceting designs by Andrew Brown

RI = 1.54

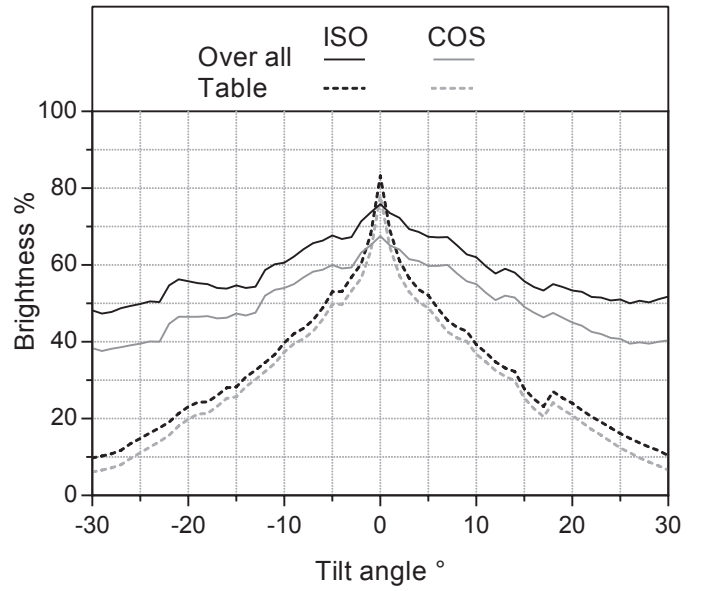
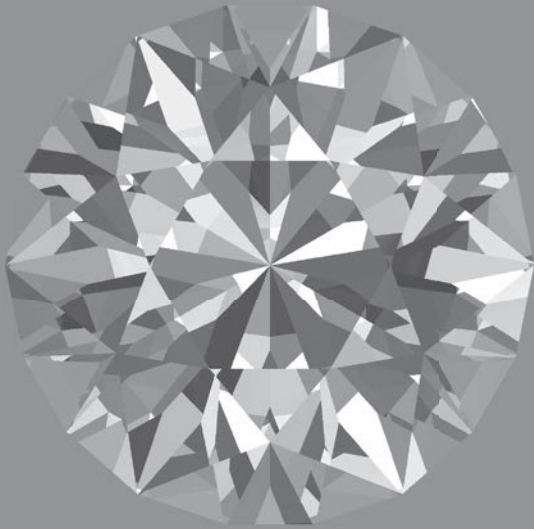

RI = 1.76

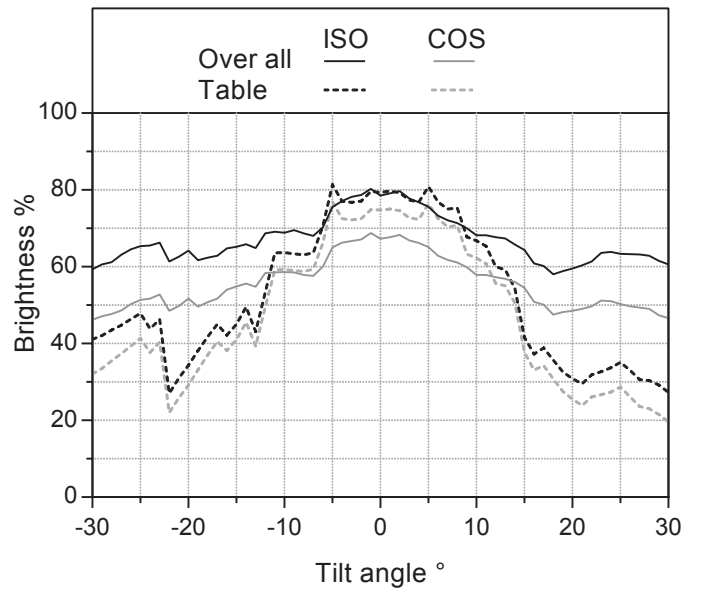
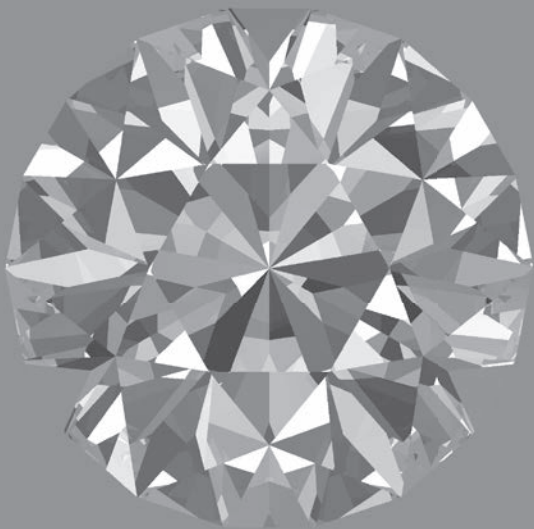

RI = 2.16

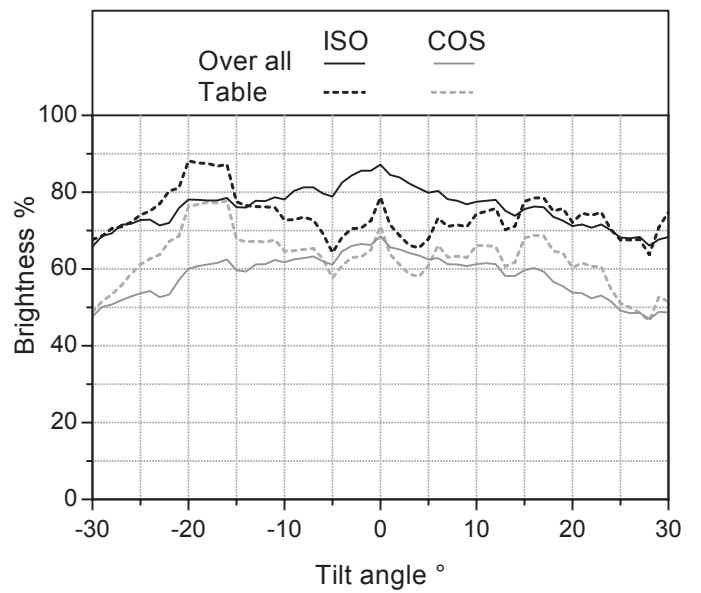

11. Rectangle

Design name: 150 Emerald

Number of facets: 37

Description:

This is a fine, fairly easy-to-cut, simple emerald design. It uses a preform to set the girdle outline, which is a great learning step for the beginner. The preform tiers are then cut away by the pavilion facets.

Notes:

- After cutting the preform and setting the girdle outline of the stone, be sure to measure your rough so you position the girdle with enough material to cut all the pavilion tiers. That way, you won't need to go back and recut, as the preform tiers may only be cut away late in the pavilion cutting sequence. You will need to cut away the TCP formed by the preform, not meet it.
- When cutting the crown, if you run out of material, the crown can be tangent-ratioed lower without changing the pavilion angles.

150 Emerald

AIB261

© Andrew Brown - July 2022

Design Information	
Pavilion facets	16
Girdle facets	8
Crown facets	12+1
Total facets	37
Index gear	96
Symmetry	2-fold mirror image
RI range	1.54 to 1.90
RI diagram	1.54 to 1.70
L/W = 1.504	T/W = 1.005
U/W = 0.501	P/W = 0.568
C/W = 0.224	V/W ³ = 0.640

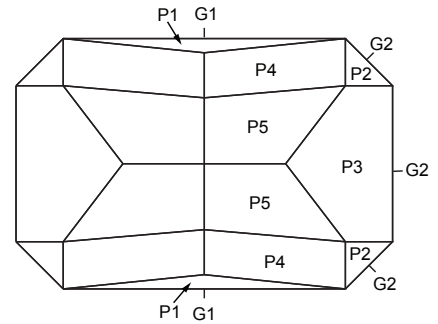
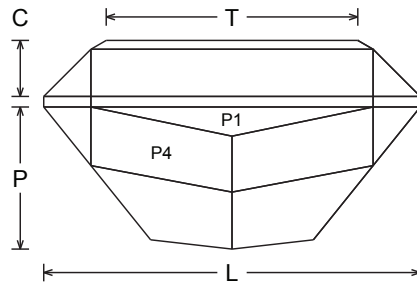
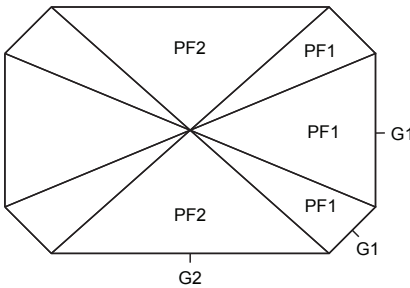
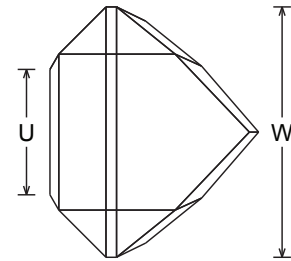
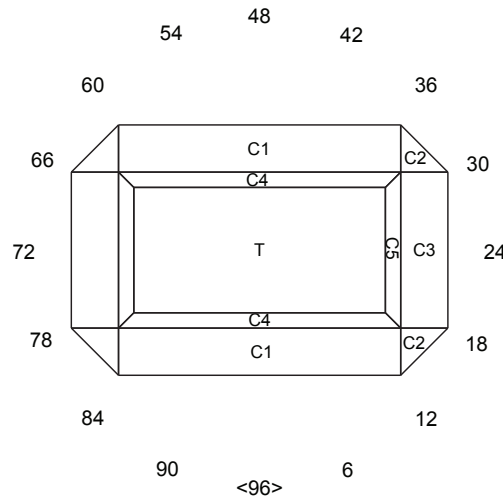

Pavilion *A = RI 1.54 to 1.70 B = RI 1.70 to 1.90

Facets	A	B	Index	Instructions
PF1	21.00°	21.00°	12-24-36-60-72-84	Form a TCP
PF2	30.00°	30.00°	96-48	Meet TCP
G1	90.00°	90.00°	12-24-36-60-72-84	Set stone size
G2	90.00°	90.00°	96-48	Meet G1, PF1, PF2
P1	64.00°	64.00°	96-48	Establish a level girdle
P2	60.36°	60.36°	12-36-60-84	Meet G1, G2, P1. Maintain a level girdle
P3	51.17°	51.17°	24-72	Meet G2, P2
P4	51.23°	51.23°	01-47-49-95	Meet G1, G2, P1, P2. Forms TCP if material is available
P5	41.08°	41.08°	02-46-50-94	Meet P2, P3, P4. Form FCP

Crown *A = RI 1.54 to 1.70 B = RI 1.70 to 1.90

Facets	A	B	Index	Instructions
C1	45.00°	40.42°	96-48	Establish girdle width
C2	54.74°	50.31°	12-36-60-84	Meet G1, G2, C1. Maintain girdle width
C3	45.00°	40.42°	24-72	Meet G1, C2. Maintain girdle width
C4	30.00°	26.19°	96-48	Meet C1, C2, C3
C5	30.00°	26.19°	24-72	Meet C1, C2, C3, C4
T	0.00°	0.00°	Table	Float in table as shown in the diagram

Please visit facetingdesigns.com for more faceting designs by Andrew Brown

RI = 1.54

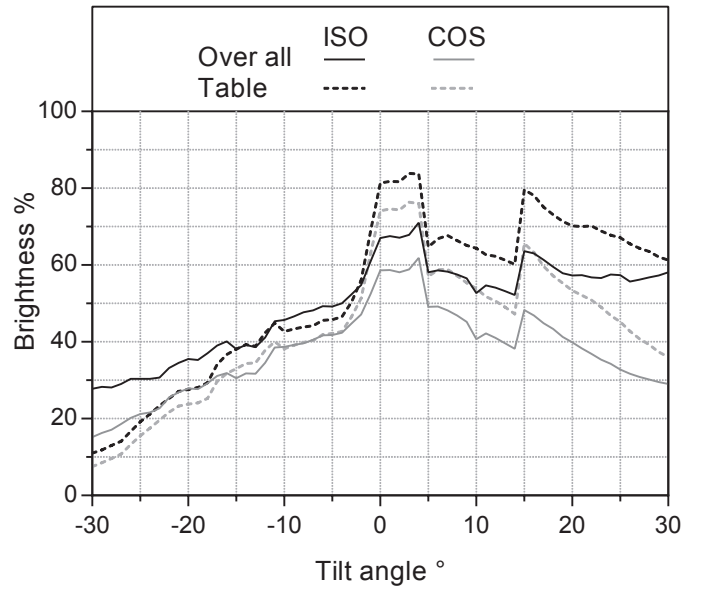
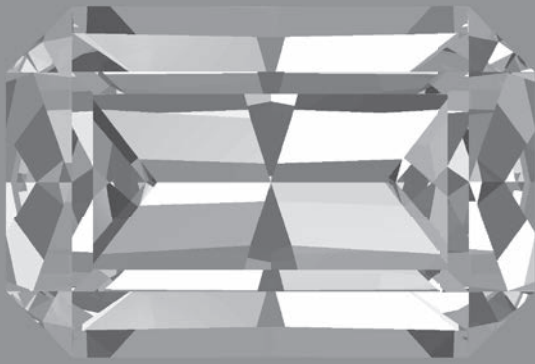

RI = 1.76

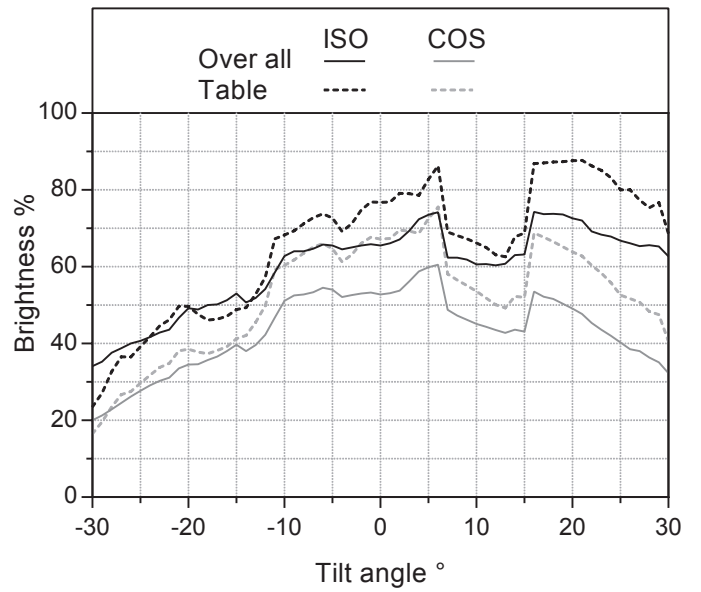
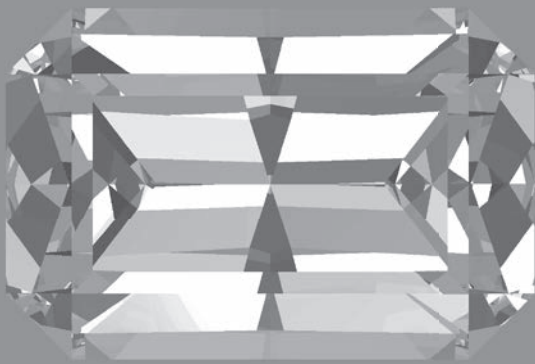

RI = 1.90

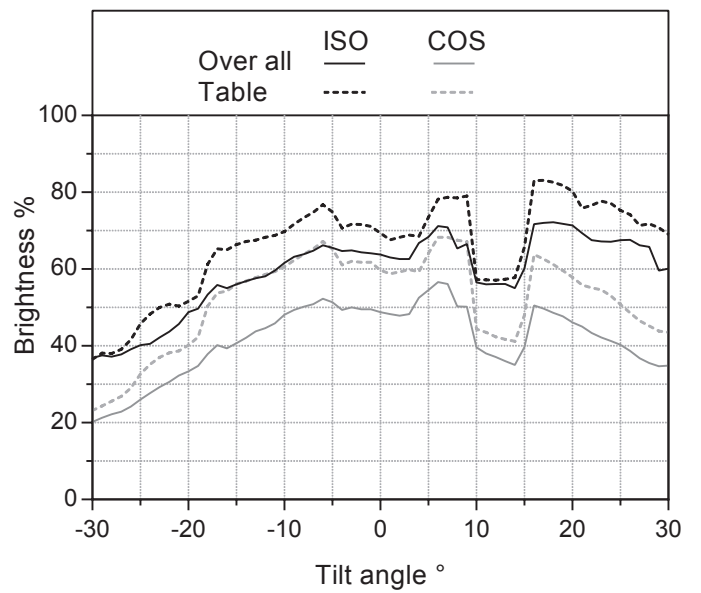
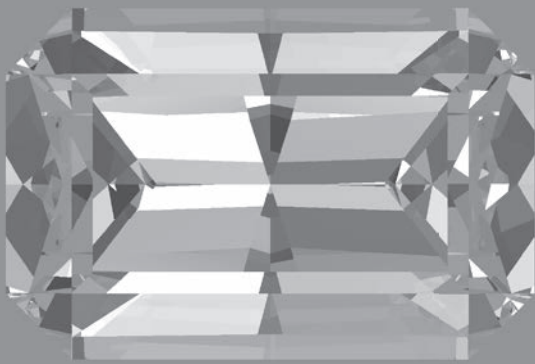

12. Hexagon

Design name: Frost Star Hex

Number of facets: 79

Description:

The last stone is a more challenging design. It uses facet frosting on the pavilion to create the main pattern. Frosting is the textured finish of one or more facets of a faceted gem. Facets to frost are highlighted by using a bold font in the design cutting instructions. I find using a worn 800 grit bronze sintered lap produces a good frosted finish. I really like frosting as a design tool. I usually use a lap course enough to create a bright frosting effect yet fine enough that chipping or scratching is not visible to the eye.

Notes:

- Take some time to experiment and practice on a test stone before choosing the lap you use to create the frosting effect.
- You will notice my “Cut Slowly” comments on pavilion tiers P3, P4 and P5. Take care cutting in these tiers as they will cut VERY fast. You will probably only need to cut tiers P3 and P5 with the lap you are using for the frosted effect. I would recommend polishing pavilion tiers P1 and P2 before cutting P3. Polish P4 before cutting P5. Try and get the frosted facets the same as the diagram. Do not leave them larger than shown in the diagram or the pattern they produce will not be as distinct. You will notice on the front cover photo, I have very slightly over-cut tier P5, as I was cutting with a head shield. I think you will achieve a better result by checking your cutting/polishing of P3, P4, and P5 using a hand lens.

Frost Star Hex

AIB262

© Andrew Brown
July 2022

Design Information	
Pavilion facets	42
Girdle facets	6
Crown facets	30+1
Total facets	79
Index gear	96
Symmetry	6-fold mirror image
RI range	1.54 to 2.30
RI diagram	1.54 to 1.90
L/W = 1.155	T/W = 0.740
U/W = 0.740	P/W = 0.528
C/W = 0.208	V/W ³ = 0.329

Note: Frosted facet indexes are indicated by **bold** text in the cutting instructions.

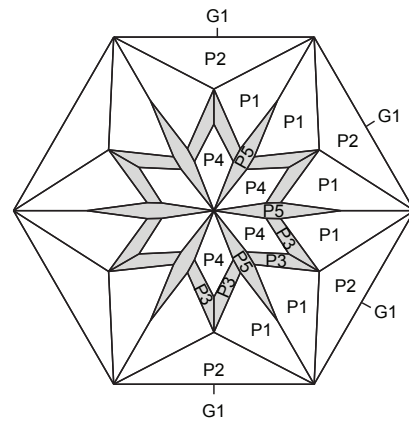
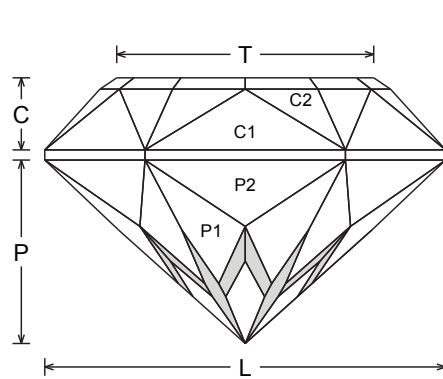
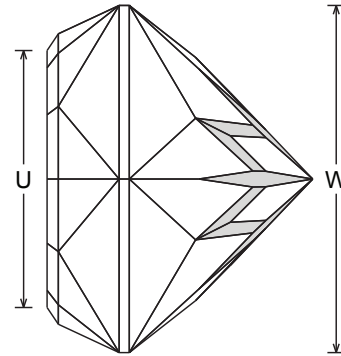
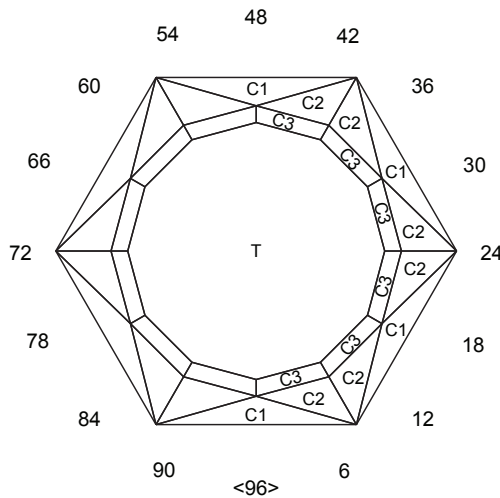

Pavilion *A = RI 1.54 to 1.90 B = RI 1.90 to 2.30

Facets	A	B	Index	Instructions
P1	45.75°	45.75°	02-14-18-30-34-46-50-62-66-78-82-94	Form a TCP
G1	90.00°	90.00°	96-16-32-48-64-80	Set stone size
P2	51.92°	51.92°	96-16-32-48-64-80	Meet G1, P1. Establish a level girdle
P3	44.69°	44.69°	01-15-17-31-33-47-49-63-65-79-81-95	Meet P1, P2 [Cut slowly, Frost]
P4	43.64°	43.64°	96-16-32-48-64-80	Float in tier as shown in the diagram. Form FCP [Cut slowly]
P5	41.86°	41.86°	08-24-40-56-72-88	Meet FCP [Cut very slowly, Frost]

Crown *A = RI 1.54 to 1.90 B = RI 1.90 to 2.30

Facets	A	B	Index	Instructions
C1	65.00°	61.00°	96-16-32-48-64-80	Establish girdle width
C2	48.75°	43.81°	04-12-20-28-36-44-52-60-68-76-84-92	Meet G1, C1
C3	34.87°	30.38°	04-12-20-28-36-44-52-60-68-76-84-92	Meet C1, C2
T	0.00°	0.00°	Table	Float in table as shown in the diagram

Please visit facetingdesigns.com for more faceting designs by Andrew Brown

RI = 1.54

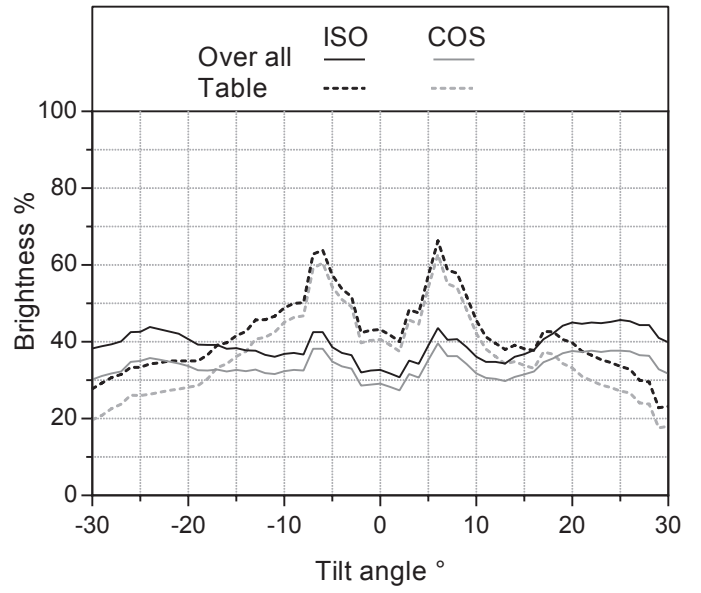
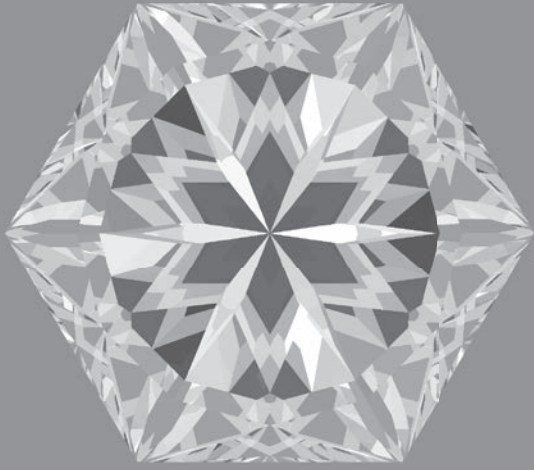

RI = 1.76

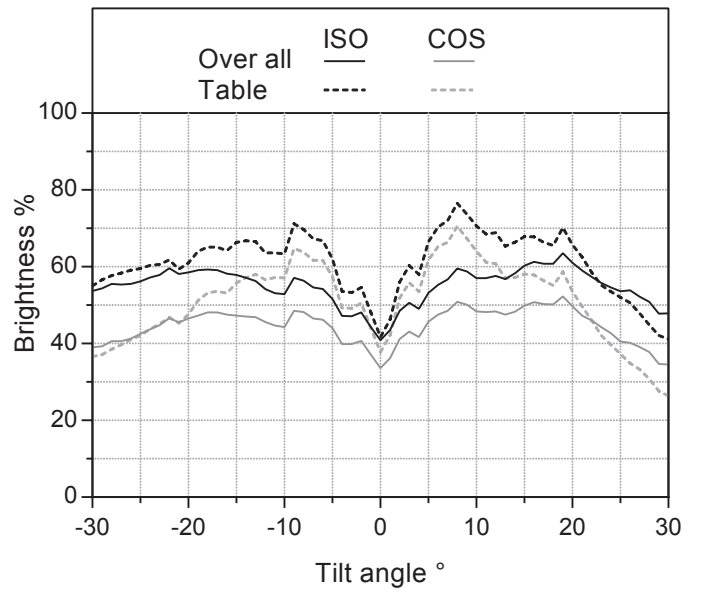

RI = 2.16

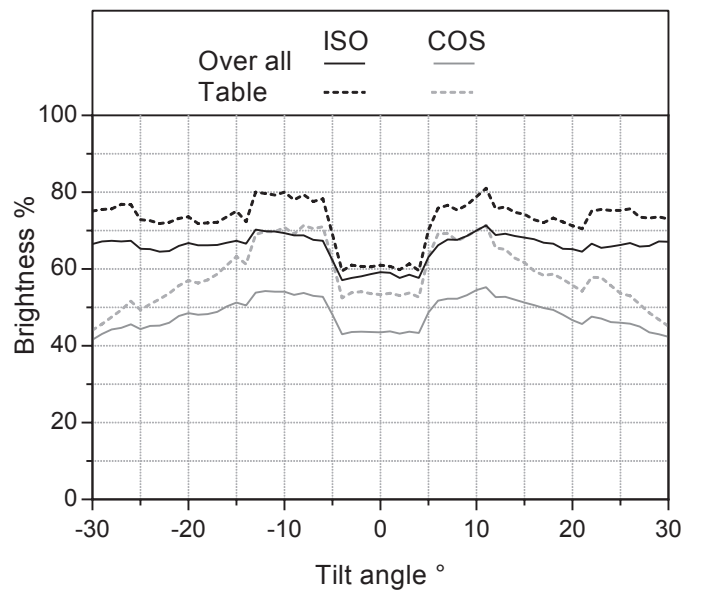

This book contains twelve easy-to-cut faceting designs by Andrew Brown and valuable faceting advice for those beginning their faceting journey. Mark Oros of Hashnu Stones & Gems LLC shares insights on faceting your first gemstones and provides excellent advice on selecting and purchasing rough. The designs have been presented in order of increasing difficulty, slowly introducing the beginner to different faceting styles while cutting a wide range of shapes.

More faceting designs by Andrew Brown can be found at facetingdesigns.com

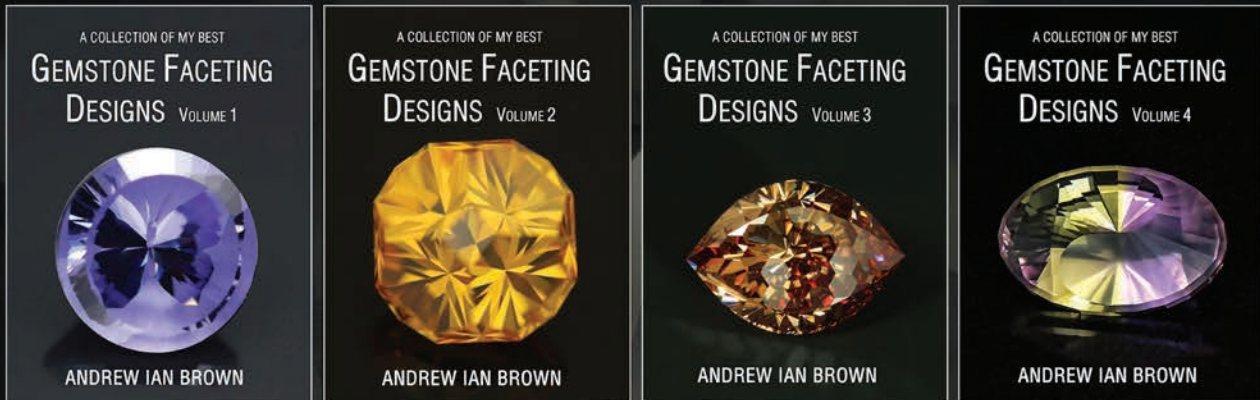

Hashnu Stones & Gems is a full service lapidary studio providing private gemstone faceting lessons and ULTRA TEC equipment. Mark is available to help you get started faceting gemstones and to work with you on setting up your lapidary/faceting studio with ULTRA TEC faceting machines. Please feel free to contact Mark at mark@hashnustones.com

